



# Bifurcations of Systems with Structurally Unstable Homoclinic Orbits and Moduli of $\Omega$ -Equivalence

S. V. GONCHENKO, L. P. SHIL'NIKOV,

O. V. STEN'KIN AND D. V. TURAEV

Institute for Applied Mathematics & Cybernetics

Ul'janova st. 10, 603005, Nizhny Novgorod, Russia

**Abstract**—Bifurcations of both two-dimensional diffeomorphisms with a homoclinic tangency and three-dimensional flows with a homoclinic loop of an equilibrium state of saddle-focus type are studied in one- and two-parameter families. Due to the well-known impossibility of a complete study of such bifurcations, the problem is restricted to the study of the bifurcations of the so-called low-round periodic orbits. In this connection, the idea of taking  $\Omega$ -moduli (continuous invariants of the topological conjugacy on the nonwandering set) as the main control parameters (together with the standard splitting parameter) is proposed. On this way, new bifurcational effects are found which do not occur at a one-parameter analysis. In particular, the density of cusp-bifurcations is revealed.

**Keywords**—Bifurcation, Homoclinic tangency, Modulus.

## 1. INTRODUCTION

As it is well known, the development of the theory of global bifurcations of multidimensional systems was started in 1960's. In particular, there was discovered a remarkable phenomenon [1,2] that a multidimensional system with a homoclinic loop of a saddle equilibrium state can possess an infinite number of periodic orbits, in distinction with the two-dimensional case. The first example of such complicated behavior is given by a homoclinic loop of an equilibrium state of saddle-focus type (Figure 1) in a three-dimensional space. Such equilibrium state has the characteristic roots  $-\lambda \pm i\omega$  and  $\gamma$ , where  $\gamma$ ,  $\lambda$ , and  $\omega$  are positive; besides, the so-called saddle index  $\rho = \lambda/\gamma$  is less than unity.

It was found in [1,2] that the structure of the set  $N$  composed by the orbits lying entirely in a small neighborhood of the homoclinic loop is not just nontrivial but it also depends essentially on the value of  $\rho$ . This dependence is such that, when  $\rho$  varies continuously, the structure of the set  $N$  permanently varies in any one-parameter family  $X_\rho$  of systems holding a saddle-focus homoclinic loop.<sup>1</sup>

In modern terms, the results of [1,2] imply that the value  $\rho$  is a *modulus* of the  $\Omega$ -equivalence of systems with a homoclinic loop of a saddle-focus. Recall the following definition.

**DEFINITION.** We say that a system  $X$  has a *modulus* if, in the space of dynamical systems, a Banach subspace  $\mathcal{M}$  passes through  $X$ , and on  $\mathcal{M}$  a locally nonconstant continuous functional  $h$  is defined such that, in order for two systems  $X_1$  and  $X_2$  from  $\mathcal{M}$  to be equivalent, it is necessary

This work was supported by EC-Russia Collaborative Project ESPRIT-P9282-ACTCS, by the INTAS Grant No. 93-0570 ext. and by the Russian Foundation of Fundamental Researches, Grant No. 96-01-01135.

<sup>1</sup>In particular, it was established in [3,4] that the values of  $\rho$  for which  $X_\rho$  has a structurally unstable periodic orbit compose a dense set.

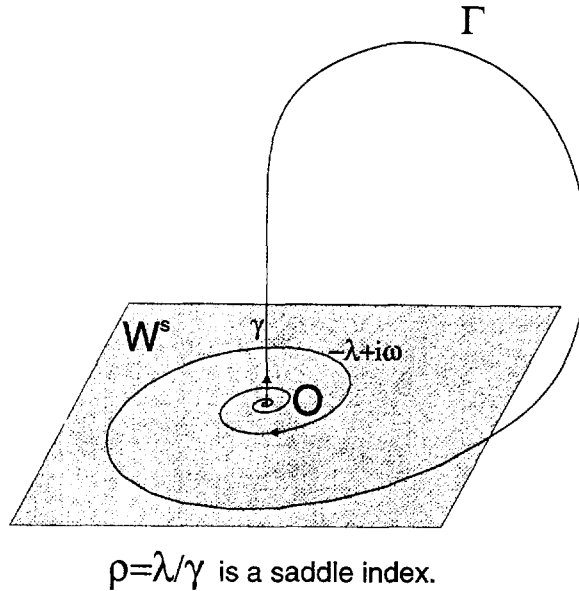

Figure 1. A three-dimensional flow  $X$  with the homoclinic loop  $\Gamma$  of the equilibrium state  $O$  of saddle-focus type (i.e., the equilibrium state  $O$  possesses characteristic roots  $-\lambda \pm i\omega$  and  $\gamma$ , where  $\lambda$ ,  $\gamma$ , and  $\omega$  are positive). Shil'nikov has shown that if the value  $\rho = \lambda/\gamma$  is less than 1, then the set  $N$  of orbits lying entirely in a small neighborhood of  $\Gamma$  has a nontrivial structure which depends essentially on the value of  $\rho$ .

that  $h(X_1) = h(X_2)$ . We shall say that  $X$  has at least  $m$  moduli if a Banach subspace passes through  $X$  on which  $m$  independent moduli are defined, and that  $X$  has a countable number of moduli if  $X$  has an arbitrary finite number of moduli.

Among different types of equivalences in the space of dynamical systems, the most known are the topological and the  $\Omega$ -equivalence (the topological equivalence on nonwandering sets). The *topological* moduli in systems with simple dynamics were discovered by Palis [5] for diffeomorphisms of a plane which have an orbit of heteroclinic tangency. Figure 2a represents such a diffeomorphism. It has two saddle fixed points  $O_1$  and  $O_2$  with multipliers  $\lambda_i$  and  $\gamma_i$ , where  $|\lambda_i| < 1$ ,  $|\gamma_i| > 1$  ( $i = 1, 2$ ). It also has a heteroclinic orbit  $\Gamma_0$  at the points of which the manifolds  $W^u(O_2)$  and  $W^s(O_1)$  have a tangency. Palis established that two such diffeomorphisms  $f$  and  $f'$  can be topologically conjugated in some neighborhoods  $U(\bar{\Gamma}_0)$  and  $U'(\bar{\Gamma}'_0)$  only in the case where the values of the invariant  $\alpha = -\ln |\lambda_2| / \ln |\gamma_1|$  are the same for  $f$  and  $f'$ .

This means that  $\alpha$  is a modulus of the topological equivalence for diffeomorphisms with a heteroclinic tangency. At the same time, any two diffeomorphisms of the Palis example are  $\Omega$ -conjugate; i.e., the value  $\alpha$  is not a modulus with respect to the  $\Omega$ -equivalence.

If we identify the saddles  $O_1$  и  $O_2$ , we get a diffeomorphism with a homoclinic tangency (Figure 2b). The invariant  $\alpha$  is equal in this case to the value which is traditionally denoted as  $\theta$ :

$$\theta = -\frac{\ln |\lambda|}{\ln |\gamma|},$$

where  $\lambda$  and  $\gamma$  are the multipliers of  $O$ .

Note that in distinction with the heteroclinic situation, the invariant  $\theta$  may be a modulus not only for the topological but also for the  $\Omega$ -equivalence. It should be mentioned here, that topological moduli appear, mainly, as obstacles to the existence of a conjugating homeomorphism, whereas  $\Omega$ -moduli have an essentially different sense. To our opinion,  $\Omega$ -moduli should be considered as parameters determining the structure of the nonwandering set. Historically, it is exactly the context in which  $\Omega$ -moduli were found (the mentioned value  $\rho$  for a saddle-focus

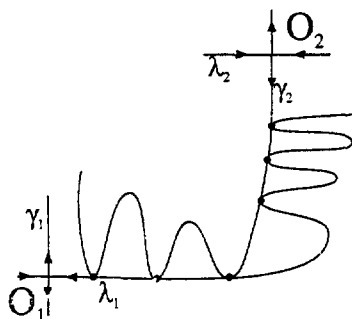

(a) A two-dimensional diffeomorphism with a heteroclinic tangency is represented. It possesses two saddle fixed points  $O_1$  and  $O_2$  with multipliers  $\lambda_i$  and  $\gamma_i$ , where  $|\lambda_i| < 1$ ,  $|\gamma_i| > 1$ ,  $i = 1, 2$ . There exists also a structurally unstable heteroclinic orbit  $\Gamma_0$  at the points of which the manifolds  $W^u(O_2)$  and  $W^s(O_1)$  are tangent. Palis established that two such diffeomorphisms  $f$  and  $f'$  may be topologically conjugate only in the case if the value  $\alpha = -\ln |\lambda_2| / \ln |\gamma_1|$  is the same for  $f$  and  $f'$ .

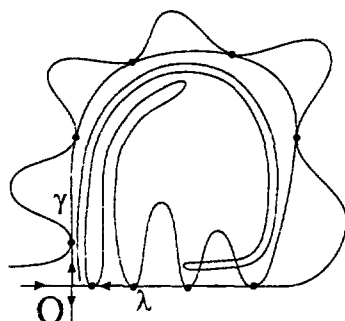

(b) A two-dimensional diffeomorphism with a homoclinic tangency is represented. It has a saddle fixed point  $O$  with multipliers  $\lambda$  and  $\gamma$ , where  $|\lambda_i| < 1$ ,  $|\gamma_i| > 1$ ,  $i = 1, 2$ . It possesses also a structurally unstable periodic orbit  $\Gamma$  at the points of which the manifolds  $W^u(O)$  and  $W^s(O)$  are tangent. The value  $\theta = -\ln |\lambda| / \ln |\gamma|$  introduced by Gavrilov and Shil'nikov is an analogue of the invariant  $\alpha$ . Note that here, in distinction with a heteroclinic situation, the value  $\theta$  may be a modulus of the  $\Omega$ -equivalence.

Figure 2.

homoclinic loop and the value  $\theta$  for homoclinic tangencies [6] essentially earlier than the notion of a topological modulus were introduced in the theory of dynamical systems.

For the bifurcation theory, importance of the study of specifically  $\Omega$ -moduli is obvious. Indeed, it is clear that if a system is perturbed so that the value of an  $\Omega$ -modulus is changed, then bifurcations of nonwandering orbits (periodic, homoclinic, etc.) must occur. First, this phenomenon was revealed in [6] at the study of bifurcations of periodic orbits on the bifurcational surface  $\mathcal{H}$  composed by systems with a quadratic homoclinic tangency. Namely, there was shown that for any one-parameter family  $X_\theta$  of systems on  $\mathcal{H}$  the values of  $\theta$  are dense for which  $X_\theta$  has a structurally unstable periodic orbit.

Note also, that  $\theta$  is not a unique  $\Omega$ -modulus for the systems with a homoclinic tangency. It was established in [7] that systems may be dense in  $\mathcal{H}$  which have a countable number of independent  $\Omega$ -moduli. Since an independent variation of the values of each of the  $\Omega$ -moduli leads to bifurcations in the nonwandering set, a joint variation of the infinite series of the  $\Omega$ -moduli may lead to *infinitely degenerate* bifurcations. Specifically, it was shown in [7] that systems with arbitrarily degenerate periodic orbits and with homoclinic orbits of any order of tangency may be dense in  $\mathcal{H}$ .

Immediately, there arise a number of problems. On one hand, systems with homoclinic tangencies compose bifurcational surfaces of codimension one in the space of dynamical systems. Therefore, such systems occur in general one-parameter families. On the other hand, the proven presence of systems with arbitrarily degenerate periodic and homoclinic orbits in an arbitrarily small neighborhood of any system with a simple homoclinic tangency shows that no finite number of control parameters is sufficient for a complete study of bifurcations of such systems. The analogous result can be also shown to hold for systems with a homoclinic loop of a saddle-focus.

In principle, we have to give up the ideology of “complete description” and to restrict ourself to the study of some most typical features and properties of such systems. Particularly, the problem of the study of *main* bifurcations in *low-parameter* families takes a sense.

In the latter sentence, we must, of course, clarify the term “main bifurcations.” We must also solve the question on the choice of the control parameters.

We will study the structure of the set  $N$  of the orbits lying entirely in a small neighborhood  $U$  of a homoclinic orbit. In the case of a two-dimensional diffeomorphism with a homoclinic tangency, this neighborhood is the union of a small disc  $U_0$ , containing the fixed point  $O$ , and a finite number of small neighborhoods of the homoclinic points which lie outside  $U_0$  (Figure 3). In the case of a three-dimensional system with a homoclinic loop of a saddle-focus, the neighborhood  $U$  is a solid torus composed by a ball  $U_0$  with the point  $O$  in the center and by a handle  $U_1$  which contains the piece of the homoclinic orbit that lies outside  $U_0$  (Figure 4). As we mentioned, the complete study of all bifurcations in  $U$  is impossible and we restrict ourself to the study of *low-round* periodic and homoclinic orbits (single-, double-, triple-, ...). A periodic orbit lying in  $U$  will be called *k-round* if it leaves  $U_0$  (and re-enters it)  $k$  times for the period. Analogously, the roundness of a homoclinic orbit is defined. The low-round orbits are, naturally, most interesting from the applied point of view. Moreover, the high-order degenerations occur only for quite high roundnesses.

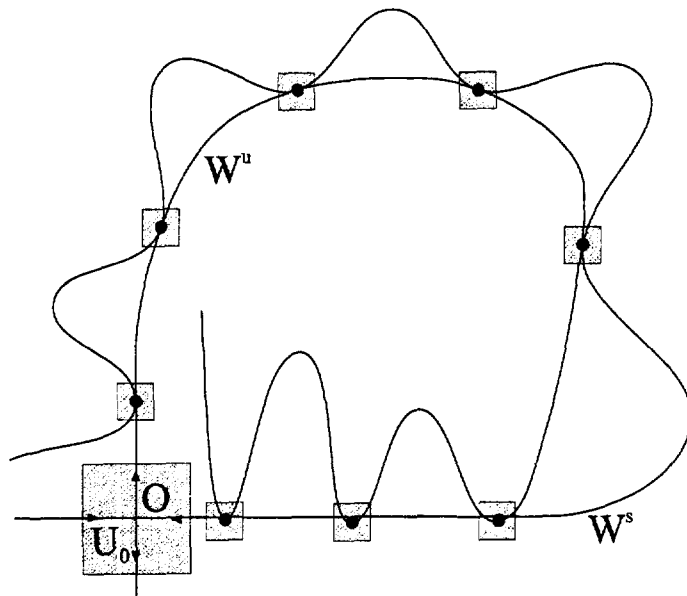

Figure 3. The neighborhood of a structurally unstable homoclinic orbit. The neighborhood  $U$  is a union of a small neighborhood  $U_0$  of the saddle fixed point  $O$  and of a finite number of small neighborhoods of homoclinic points lying outside  $U_0$ .

What concerns the right choice of the control parameters, this question has a principal meaning for the systems with complex dynamics. There is no problem with finding appropriate control parameters in the classical bifurcation theory going back to the studying of flows on a plane: here, each parameter is responsible for unfolding some definite degeneration of the system (for instance, the control parameters govern independently the splitting of separatrices, variation of values of

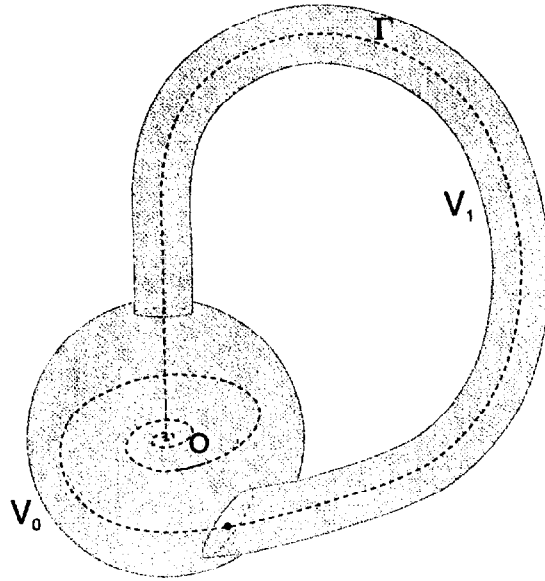

Figure 4. The neighborhood of a homoclinic loop of saddle-focus. The neighborhood  $U$  is a solid torus composed by a small neighbourhood  $U_0$  of the point  $O$  and by a handle  $U_1$  glued to  $U_0$ .

critical characteristic exponents of equilibrium states and multipliers of periodic orbits, variation of Lyapunov values, etc.). For the multidimensional systems with homoclinic tangencies, the so-called *splitting parameters* must clearly be taken as one of the main control parameters for the study of bifurcations.

However, according to what was said above about  $\Omega$ -moduli, it becomes clear that to obtain a more detailed bifurcational picture one must take  $\Omega$ -moduli as additional bifurcation parameters (or such values whose variation leads to variation of values of the  $\Omega$ -moduli).

In the present paper, we demonstrate the effectiveness of this approach to the study of main bifurcations in systems with complex dynamics for two cases:

- (1) two-dimensional diffeomorphisms with a homoclinic tangency (Section 2), and
- (2) three-dimensional systems with a homoclinic loop of a saddle-focus (Section 3).

## 2. TWO-DIMENSIONAL DIFFEOMORPHISMS WITH A HOMOCLINIC TANGENCY

### 2.1. Geometric Constructions

#### 2.1.1. The neighborhood of a structurally unstable homoclinic orbit

We consider a  $C^{r+2}$ -smooth ( $r \geq 3$ ) two-dimensional diffeomorphism  $f$  which has a saddle fixed point  $O$  with multipliers  $\lambda$  and  $\gamma$ , where  $0 < |\lambda| < 1$ ,  $|\gamma| > 1$ . We consider the case where  $|\lambda\gamma| < 1$ . The case  $|\lambda\gamma| > 1$  is reduced to that under consideration by transition to the inverse map  $f^{-1}$  instead of the initial map  $f$ ; the special case  $|\lambda\gamma| = 1$  requires a separate investigation (see, for instance, [8]).

Suppose the stable and unstable manifolds of  $O$  have a quadratic tangency at the points of a homoclinic orbit  $\Gamma$ .

Let  $U$  be a small neighborhood of the set  $O \cup \Gamma$ . The neighborhood  $U$  is the union of a small disc  $U_0$  containing  $O$  and of a finite number of small discs surrounding the points of  $\Gamma$  which are located outside  $U_0$  (Figure 3). The subject of our study is the set  $N$  of orbits of the map  $f$  that lie entirely in  $U$ .

**2.1.2. The local and global maps  $T_0$  and  $T_1$**

Let  $T_0$  be the restriction of  $f$  onto  $U_0$  (it is called *the local map*). Note that the map  $T_0$  in some  $C^{r+1}$ -coordinates  $(x, y)$  can be written in the form [9,10]

$$\bar{x} = \lambda x + f(x, y)x^2y, \quad \bar{y} = \gamma y + g(x, y)xy^2. \tag{2.1}$$

By (2.1), the equations of the local stable manifold  $W_{loc}^s$  and local unstable manifold  $W_{loc}^u$  are  $y = 0$  and  $x = 0$ , respectively. Representation (2.1) for the local map is convenient, because in these coordinates the map  $T_0^k$  for any sufficiently large  $k$  is linear in the lowest order. Specifically, we have the following representation [9,10] for the map  $T_0^k : (x_0, y_0) \mapsto (x_k, y_k)$ :

$$\begin{aligned} x_k &= \lambda^k x_0 + |\lambda|^k |\gamma|^{-k} \phi_{k1}(x_0, y_k), \\ y_k &= \gamma^{-k} y_0 + |\gamma|^{-2k} \phi_{k2}(x_0, y_k), \end{aligned} \tag{2.2}$$

where  $\phi_{k1}$  and  $\phi_{k2}$  are functions uniformly bounded at all  $k$  along with their derivatives up to the order  $r$ .

Let  $M^+(x^+, 0)$  and  $M^-(0, y^-)$  be a pair of points of  $\Gamma$  which lie in  $U_0$  and belong to  $W_{loc}^s$  and  $W_{loc}^u$ , respectively. Without loss of generality, we can assume  $x^+ > 0$  and  $y^- > 0$ . Let  $\Pi_0$  and  $\Pi_1$  be sufficiently small neighborhoods of the homoclinic points  $M^+$  and  $M^-$  such that  $T_0(\Pi_0) \cap \Pi_0 = \emptyset$  and  $T_0(\Pi_1) \cap \Pi_1 = \emptyset$ . Evidently, there exists an integer  $m$  such that  $f^m(M^-) = M^+$ . We denote the map  $f^m : \Pi_1 \rightarrow \Pi_0$  as  $T_1$  (it is called *the global map*). The map  $T_1$  can obviously be written in the form

$$\begin{aligned} \bar{x} - x^+ &= ax + b(y - y^-) + \dots, \\ \bar{y} &= cx + d(y - y^-)^2 + \dots, \end{aligned} \tag{2.3}$$

where  $bc \neq 0$  since  $T_1$  is a diffeomorphism, and  $d \neq 0$  since the tangency is quadratic.

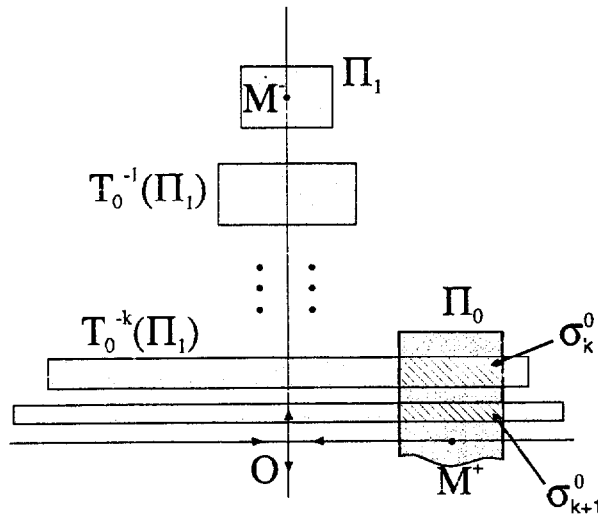

Figure 5. This figure illustrates the method of a construction of strips  $\sigma_k^0$ ,  $k = \bar{k}, \bar{k} + 1, \dots$ , which lie in  $\Pi_0$  and which are the domains of the maps  $T_0^k : \Pi_0 \rightarrow \Pi_1$ . The points of  $\Pi_0$  targeting to  $\Pi_1$  after  $k$  iterations of the map  $T_0$  belong to the set  $T_0^{-k} \cap \Pi_0$ . The neighborhood  $\Pi_1$  is contracted in  $\gamma^{-1}$  times along the vertical direction and it is expanded in  $\lambda^{-1}$  times along the horizontal direction under the action of the map  $T_0^{-1}$ . Moreover,  $T_0^{-1}(\Pi_1) \cap \Pi_1 = \emptyset$ . Respectively, the set  $T_0^{-k}(\Pi_1)$  is a narrow rectangle which is stretched along the  $x$ -axis and lies at a distance of order  $\gamma^{-k}$  from it. Besides, the rectangles  $T_0^{-k}(\Pi_1)$  and  $T_0^{-(k+1)}(\Pi_1)$  are not intersected. For sufficiently large  $k$ , the intersection  $T_0^{-k}(\Pi_1) \cap \Pi_1$  is the strip  $\sigma_k^0$  as is shown. The strips  $\sigma_k^0$  accumulate on the segment  $W^s \cap \Pi_0$  as  $k \rightarrow \infty$ .

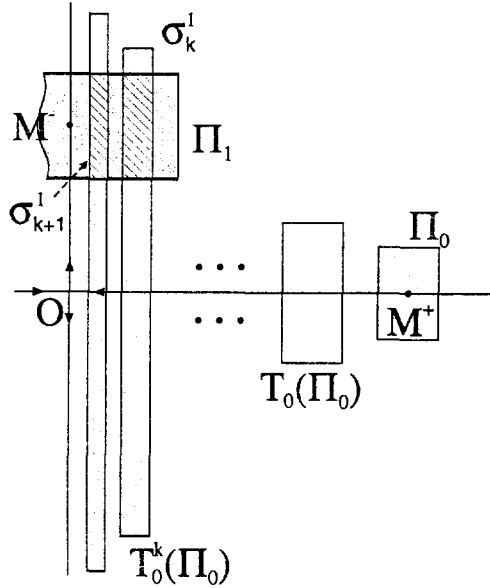

Figure 6. This figure illustrates a method of construction of the strips  $\sigma_k^1$ ,  $k = \bar{k}, \bar{k} + 1, \dots$ , which lie in  $\Pi_1$  and which are the ranges of the maps  $T_0^k : \Pi_0 \rightarrow \Pi_1$ .

**2.1.3. Strips and horseshoes**

Note that orbits of  $N$  must intersect the neighborhoods  $\Pi_0$  and  $\Pi_1$  (otherwise, these orbits would be far from  $\Gamma$ ). However, not all orbits that start in  $\Pi_0$  arrive in  $\Pi_1$ . The set of the points whose orbits get into  $\Pi_1$  fills a countable number of strips  $\sigma_k^0 = \Pi_0 \cap T_0^{-k}\Pi_1$  which accumulate on  $W^s$ . The way of constructing these strips is obvious from Figure 5. In turn, the images of the strips  $\sigma_k^0$  under the maps  $T_0^k$  give on  $\Pi_1$  a sequence of vertical strips  $\sigma_k^1$  which accumulate on  $W_{loc}^u$  (Figure 6).

Neighborhoods  $\Pi_0$  and  $\Pi_1$  may be taken so that to contain all the strips  $\sigma_k^0$  and  $\sigma_k^1$  with numbers  $k \geq \bar{k}$  and not to intersect with  $\sigma_k^0$  and  $\sigma_k^1$  for  $k < \bar{k}$ . Obviously, if  $\text{diam}\Pi_0 \cdot \text{diam}\Pi_1 \rightarrow 0$ , then  $\bar{k} \rightarrow \infty$ .

The images  $T_1\sigma_k^1$  of the strips  $\sigma_k^1$  have a shape of horseshoes accumulated on  $T_1W_{loc}^u$  as  $k \rightarrow \infty$  (Figure 7). It is clear that orbits of  $N$  must intersect  $\Pi_0$  in points lying in intersections of horseshoes  $T_1\sigma_i^1$  and strips  $\sigma_j^0$  for  $i, j \geq \bar{k}$ . Hence, the structure of  $N$  depends essentially on geometrical properties of such intersections.

**2.1.4. The types of intersections of the strips and horseshoes**

Different types of intersections of a horseshoe  $T_1\sigma_i^1$  with the strips are shown in Figure 8. The horseshoe has a regular intersection with the strip  $\sigma_j^0$ , an irregular intersection with the strip  $\sigma_k^0$  and empty intersection with the strip  $\sigma_l^0$ .

The intersection is called *regular* if the set  $T_1\sigma_i^1 \cap \sigma_j^0$  is nonempty and consists of two connected components  $\sigma_{ji}^{01}$  and  $\sigma_{ji}^{02}$  (Figure 9), and the maps  $T_{i\alpha} \equiv T_1T_0^i : \sigma_i^{0\alpha} \rightarrow \sigma_j^0$ ,  $\alpha = 1, 2$ , are saddle (i.e., they are contracting along the coordinate  $x$  and expanding along the coordinate  $y$ ). Here  $\sigma_i^{01}$  and  $\sigma_i^{02}$  are upper and lower parts of the strip  $\sigma_i^0$ . They are separated by the central part of  $\sigma_i^0$  (denoted as  $\sigma_i^{0c}$  in Figure 9) which is mapped by  $T_1T_0^i$  onto the top of the horseshoe  $T_1\sigma_i^1$ .

**2.1.5. The conditions of regular and irregular intersections of the strips and horseshoes**

It is established in [8] that if the inequality

$$d[\gamma^{-j}y^- - c\lambda^i x^+] > S_{\bar{k}}(i, j) \tag{2.4}$$

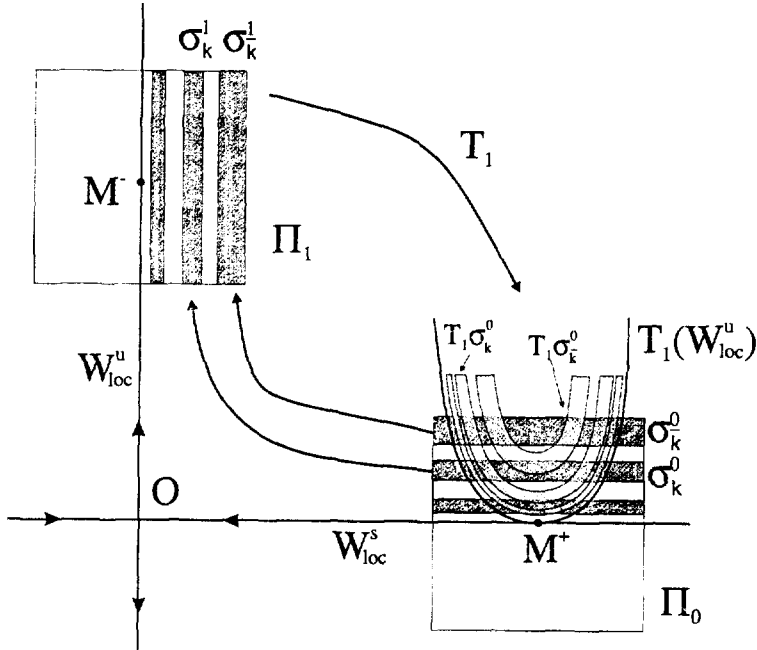

Figure 7. The images  $T_1\sigma_k^1$  of the strips  $\sigma_k^1$  have a shape of horseshoes which are accumulated on  $T_1(W_{loc}^u)$  as  $k \rightarrow \infty$ . Orbits of the set  $N$  must intersect  $\Pi_0$  in the points of intersections of the "horseshoes"  $T_1\sigma_i^1$  and the strips  $\sigma_j^0$  for  $i, j \geq \bar{k}$ .

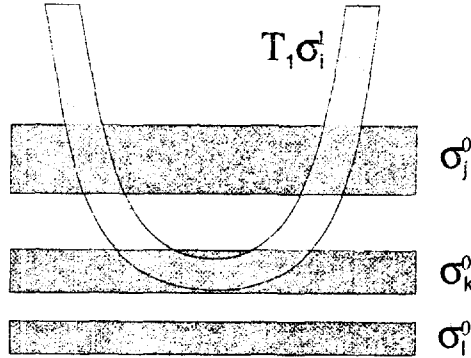

Figure 8. Various types of intersections of the "horseshoe"  $T_1\sigma_i^1$  with the strips. The horseshoe has a regular intersection with the strip  $\sigma_j^0$ ; it has an irregular intersection with the strip  $\sigma_k^0$  and an empty intersection with the strip  $\sigma_l^0$ .

is satisfied where  $S_{\bar{k}}(i, j) = S_1(|\lambda|^i + |\gamma|^{-j}) \cdot |\gamma|^{-\bar{k}/2}$ , and  $S_1$  is some positive constant independent from  $i, j$ , and  $\bar{k}$ , then the intersection of  $T_1\sigma_i^1$  with  $\sigma_j^0$  is regular.

The inequality

$$d[\gamma^{-j}y^- - c\lambda^i x^+] < -S_{\bar{k}}(i, j) \tag{2.5}$$

is a sufficient condition for an intersection of  $T_1\sigma_i^1$  and  $\sigma_j^0$  to be empty.

It is clear from (2.4) and (2.5) that the inequality

$$|d[\gamma^{-j}y^- - c\lambda^i x^+]| \leq S_{\bar{k}}(i, j) \tag{2.6}$$

is necessary in order for the horseshoe  $T_1\sigma_i^1$  to have an irregular intersection with the strip  $\sigma_j^0$ .

Inequalities (2.4)–(2.6) have a quite simple geometrical sense (Figure 10). The strip  $\sigma_j^0$  is a thin rectangle with the central line  $y = \gamma^{-j}y^-$ . The strip  $\sigma_i^1$  is a thin rectangle with the central line  $x = \lambda^i x^+$ . The strip  $\sigma_i^1$  is mapped by the map  $T_1$  onto a horseshoe with the parabola  $y = c\lambda^i x^+ + d((x - x^+)/b)^2$  as a central line. The condition  $d[\gamma^{-j}y^- - c\lambda^i x^+] > 0$  means



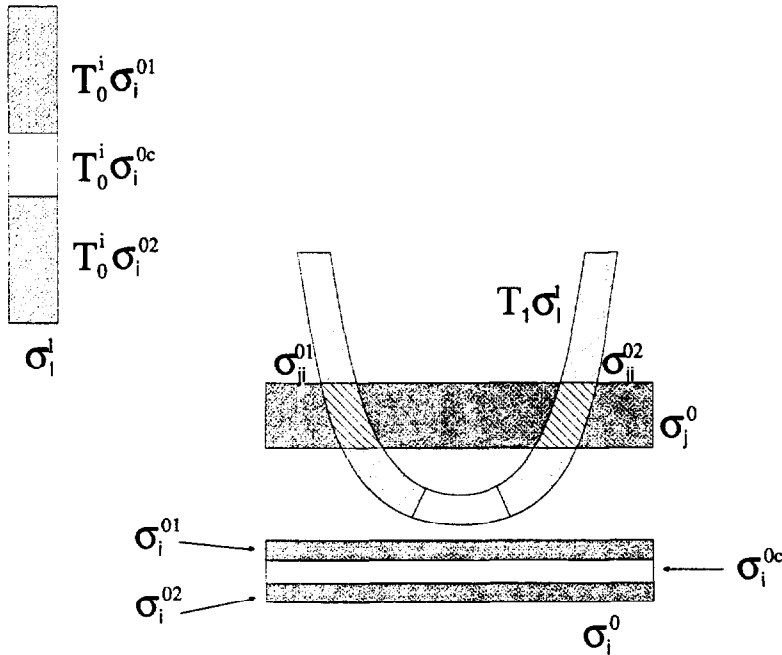

Figure 9. The case of regular intersection of the horseshoe  $T_1\sigma_i^1$  with the strip  $\sigma_j^0$ . The intersection is called regular if (a) the set  $T_1\sigma_i^1 \cap \sigma_j^0$  is nonempty and consists of two connected components  $\sigma_j^{01}$  and  $\sigma_j^{02}$ , and (b) the maps  $T_{i\alpha} \equiv T_1T_0^i : \sigma_j^{0\alpha} \rightarrow \sigma_j^0$ ,  $\alpha = 1, 2$ , are of saddle-type (i.e., they are contracting along the  $x$ -coordinate and expanding along the  $y$ -coordinate). Here,  $\sigma_j^{01}$  and  $\sigma_j^{02}$  are upper and lower parts of the strip  $\sigma_j^0$ . They are separated by the central part  $\sigma_j^{0c}$  of  $\sigma_j^0$  which is mapped by  $T_1T_0^i$  onto the top of the horseshoe  $T_1\sigma_i^1$ .

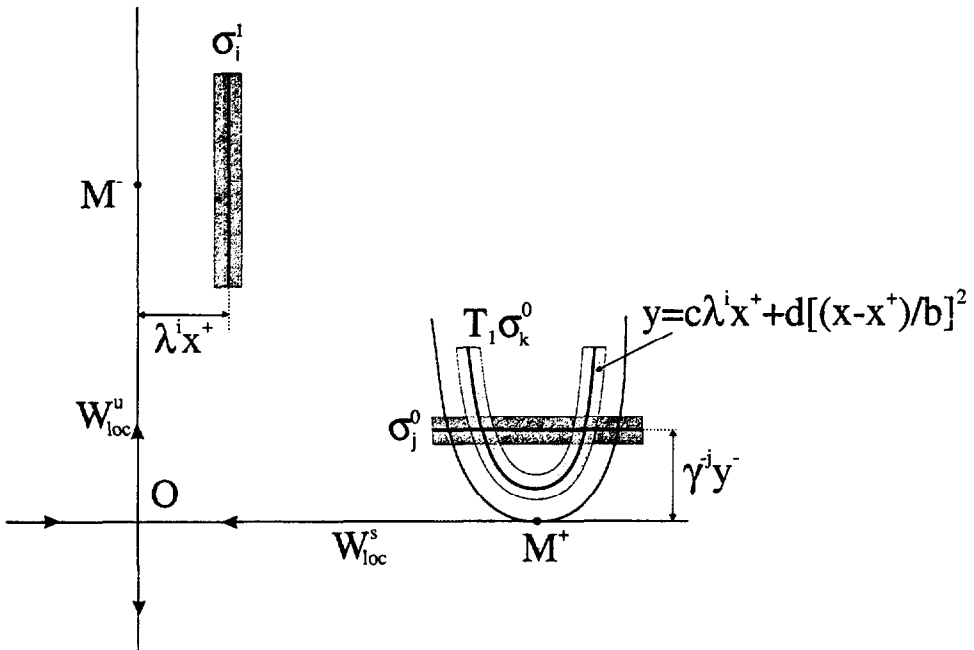

Figure 10. The strip  $\sigma_j^0$  is a thin rectangle with the central line  $y = \gamma^{-j}y^-$ . The strip  $\sigma_i^1$  is a thin rectangle with the central line  $x = \lambda^i x^+$ . The strip  $\sigma_i^1$  is mapped by the map  $T_1$  onto a horseshoe with the parabola  $y = c\lambda^i x^+ + d((x - x^+)/b)^2$  as a central line.

that the straight line  $y = \gamma^{-j}y^-$  and the parabola intersect in two points, and the condition  $d[\gamma^{-j}y^- - c\lambda^i x^+] < 0$  means that they have no intersection. The coefficient  $S_k^i(i, j)$  in (2.4)–(2.6) is due to the nonzero thicknesses of the strip and horseshoe.

**2.1.6. Codes**

Let  $Q$  be an orbit lying in  $U$  entirely and nonasymptotic to  $O$ . This orbit intersects  $\Pi_0$  in an infinite sequence of points  $M_s$ . Each point  $M_s$  belongs to some strip  $\sigma_{k_s}$ ; hereat, successive points  $M_s$  and  $M_{s+1}$  are connected by the relation

$$M_{s+1} = T_1 T_0^{k_s}(M_s).$$

The infinite sequence of integers  $\{k_s\}$  is called a *natural code* of the orbit  $Q$ .

DEFINITION. A pair of integers  $(i, j)$  is called *inadmissible* if  $i < \bar{k}$ , or  $j < \bar{k}$ , or inequality (2.5) is fulfilled. Otherwise, the pair  $(i, j)$  is called *admissible*. An admissible pair is called *regular* if it satisfies inequality (2.4). A sequence of integers  $\{k_s\}$  is called *inadmissible* if at least one of the pairs  $(k_s, k_{s+1})$  is inadmissible, and it is called *admissible* otherwise. An admissible sequence  $\{k_s\}$  is called *regular* if each pair  $(k_s, k_{s+1})$  is regular.

PROPOSITION 2.1.

- (1) For each orbit  $Q$  lying in  $U$  entirely, the code is an admissible sequence.
- (2) If a sequence  $\{k_s\}$  is regular, then there exists a continuum of saddle orbits in  $N$  which have the given sequence as the code.

The first part of this assertion is evident because  $M_{s+1} \in T_1 \sigma_{k_s}^1 \cap \sigma_{k_{s+1}}^0$ . The second part of the assertion was proved in [6,11].

The last is connected with the fact that inequalities (2.4) guarantee that the intersection  $T_1 \sigma_{k_s}^1 \cap \sigma_{k_{s+1}}^0$  is regular. It consists of two connected components  $\sigma_{k_{s+1}k_s}^{01}$  and  $\sigma_{k_{s+1}k_s}^{02}$  (Figure 9), and points belonging to different components may be distinguished. Therefore, for the orbits in  $U$  with the regular natural codes, a more precise code can be constructed. Namely, it is a sequence  $\{(k_s, \alpha_s)\}$  ( $\alpha_s \in \{1, 2\}$ ) such that the point  $M_s$  belongs to  $\sigma_{k_{s+1}k_s}^{0\alpha_s} \subset \sigma_{k_s}^0$  (we will also use an equivalent notation for the code  $\{(k_s, \alpha_s)\}$  as a sequence of the symbols "0", "1," and "2":

$$\dots, \alpha_{s-1}, \overbrace{0, \dots, 0}^{k_s}, \alpha_s, \overbrace{0, \dots, 0}^{k_{s+1}}, \alpha_{s+1}, \dots).$$

By the definition,

$$M_{s+1} = \tilde{T}_{k_s \alpha_s} M_s, \tag{2.7}$$

where the map  $\tilde{T}_{k_s \alpha_s} \equiv T_1 T_0^{k_s} |_{\sigma_{k_s}^{0\alpha_s}}$  is saddle. By the "lemma on a saddle fixed point in a countable product of spaces" from [12], there exists a unique sequence of points satisfying equation (2.7). Thus, to each code  $\{(k_s, \alpha_s)\}$  where  $\{k_s\}$  is regular and  $\{\alpha_s\}$  is an arbitrary fixed sequence of the symbols "1" and "2," there corresponds a unique orbit  $Q \in N$  (the set of the orbits which correspond to different sequences  $\{\alpha_s\}$  has the cardinality of continuum).

Note also that if a nonsaddle orbit exists in  $N$ , then its code  $\{k_s\}$  must be such that inequality (2.6) is satisfied for at least one of the pairs ( $i = k_s, j = k_{s+1}$ ).

**2.2. The Types of Two-Dimensional Diffeomorphisms with a Homoclinic Tangency**

Thus, an analysis of the structure of integer solutions of inequalities (2.4)–(2.6) is an essential part of the study of orbits of the set  $N$ . The sets of such solutions obviously depend on the signs of parameters  $\lambda, \gamma, c$ , and  $d$ . Geometrically, it is connected with the fact that the signs of these values determine the character of the reciprocal position of the manifolds  $W_{loc}^s$  and  $T_1 W_{loc}^u$  in a neighborhood of the homoclinic point  $M^+$ . We restrict ourself to the case of positive  $\lambda$  and  $\gamma$  (see footnote<sup>2</sup>. Different cases possible here, in dependence on signs of  $c$  and  $d$  are shown in Figure 11.

According to [6], the diffeomorphisms under consideration are divided into the three classes for which the structure of the set  $N$  is essentially different.

<sup>2</sup>The cases of different signs of  $\lambda$  and  $\gamma$  are considered, for instance, in [9,10].

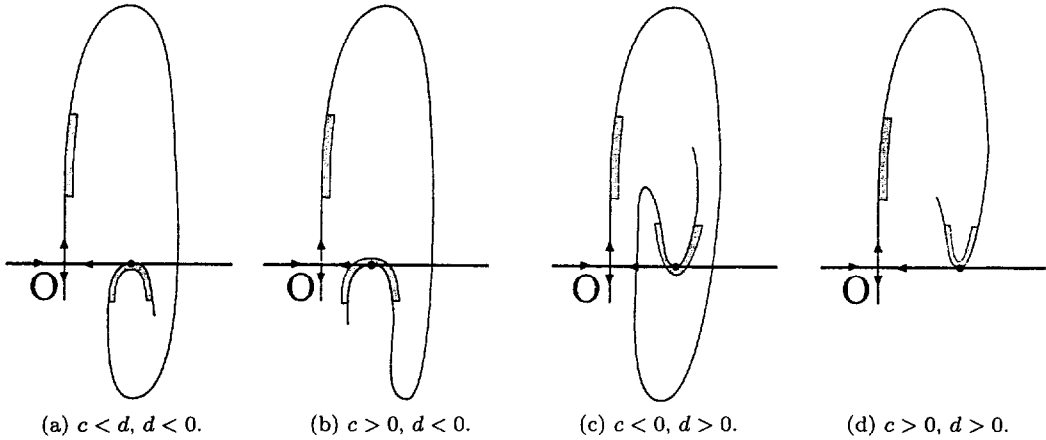

Figure 11. Various types of diffeomorphisms with a homoclinic tangency in the case where both  $\lambda$  and  $\gamma$  are positive. These types correspond to different cases of a reciprocal position of the stable and unstable manifolds which depends on the signs of the values  $c$  and  $d$ . When  $d$  is negative,  $W^u$  is tangent to  $W^s_{loc}$  from below (a) and (b); when  $d$  is positive,  $W^u$  is tangent to  $W^s_{loc}$  from above (c) and (d). The sign of the value  $c$  determines how the shaded semineighborhood of the homoclinic point  $M^-$  is mapped onto the neighborhood of the point  $M^+$ .

**2.2.1. Systems of the first class**

The systems of the first class are those for which  $\lambda > 0, \gamma > 0, d < 0$ . The following theorem takes place.

**THEOREM 1.** [6] *Let  $f$  be a diffeomorphism of the first class. Then the set  $N$  is trivial:  $N = \{O, \Gamma\}$ .*

This result can be obtained from the analysis of the set of integer solutions of inequalities (2.4)–(2.6): one can prove that if  $\lambda > 0, \gamma > 0, d < 0$ , any sequence  $\{k_s\}$  is inadmissible. Geometrically, this can be verified in the following way. If  $c < 0, d < 0$ , then the horseshoes  $T_1\sigma_i^1$  and the strips  $\sigma_j^0$  do not intersect since they lie at the opposite sides from  $W^s_{loc}$  (Figure 12a). Thus, in this case, the set  $N$  has a trivial structure indeed:  $N = \{O, \Gamma\}$ .

In the case  $c > 0, d < 0$  (i.e., when “parabola”  $T^1W^u_{loc}$  is tangent to  $W^s_{loc}$  from below; see Figure 12b), the set  $N$  has a trivial structure also. It is connected with the fact that here the intersection  $T_1\sigma_i^1 \cap \sigma_j^0$  may be nonempty only for  $j > i$ . Indeed, the strip  $\sigma_j^0$  lies at a distance of an order  $\gamma^{-j}$  from  $W^s_{loc}$  and the top of the horseshoe  $T_1\sigma_i^1$  lies at a distance of an order  $\lambda^i$  from  $W^s_{loc}$  (Figure 12b). Since  $\lambda\gamma < 1$ , it follows that  $\lambda^i \ll \gamma^{-i}$ , so any horseshoe  $T_1\sigma_i^1$  lies below the corresponding strip  $\sigma_i^0$ , and hence, below any strip  $\sigma_j^0$  with  $j < i$ . As a consequence, we have that the negative semiorbit of any initial point on  $\Pi_0$  (except  $M^+$ ) leaves the neighbourhood  $U$ .

**2.2.2. Systems of the second class**

The systems of the second class are those for which  $\lambda > 0, \gamma > 0, c < 0, d > 0$ . In this case, evidently, inequality (2.4) is fulfilled for any sufficiently large  $i$  and  $j$ ; i.e., the intersection of  $T_1\sigma_i^1$  with  $\sigma_j^0$  is regular for any  $i, j \geq \bar{k}$  (Figure 12c). Correspondingly, any sequence of integers  $k_s \geq \bar{k}$  is regular in this case. Therefore, the following statement [6] takes place.

**THEOREM 2.** *In the case  $c < 0, d > 0$ , all orbits from  $N \setminus \Gamma$  have a saddle-type and  $N$  is in one-to-one correspondence with the a quotient-system  $\Omega_0$  which is obtained from the Bernoulli scheme on three symbols  $\{0, 1, 2\}$  by identification of two homoclinic orbits:  $(\dots, 0, \dots, 0, 1, 0, \dots)$  and  $(\dots, 0, \dots, 0, 2, 0, \dots)$ .<sup>3</sup>*

<sup>3</sup>Both these two codes correspond to the orbit  $\Gamma$ .

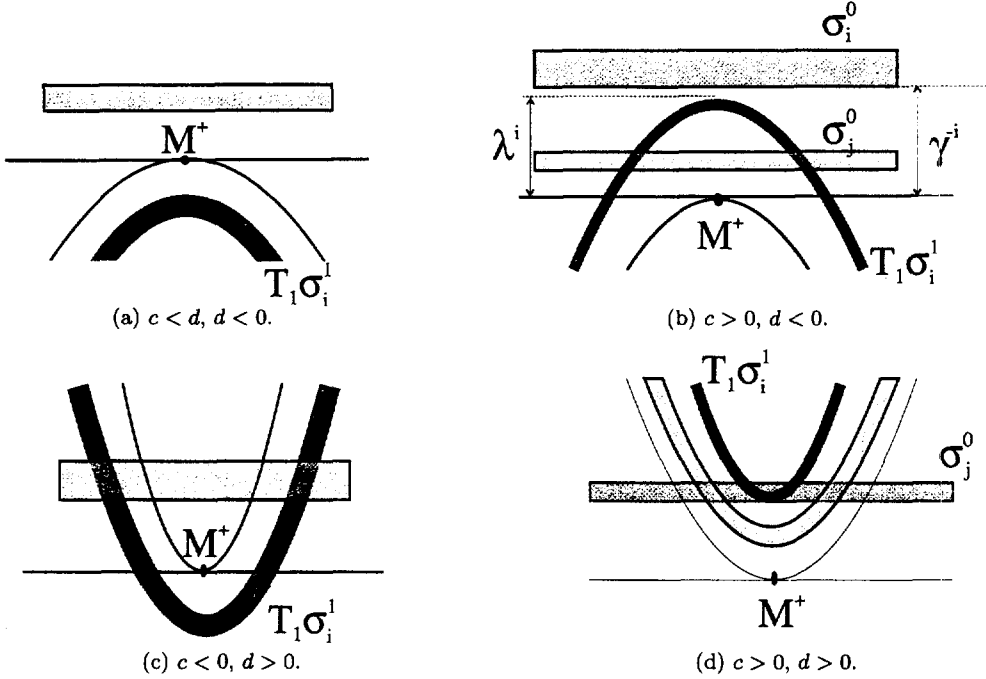

Figure 12. The reciprocal position of the strips and the horseshoes. In the case  $c < 0, d < 0$  (a), the horseshoes  $T_1\sigma_i^1$  and the strips  $\sigma_j^0$  lie from the opposite sides from  $W_{loc}^s$ . In the case  $c > 0, d < 0$  (b), any horseshoe  $T_1\sigma_i^1$  lies below its “own” strip  $\sigma_i^0$ , and hence, below any strip  $\sigma_k^0$  with  $k \leq i$ . Really, the strip  $\sigma_j^0$  lies here at a distance of order  $\gamma^{-j}$  from  $W_{loc}^s$ ; the top of the horseshoe  $T_1\sigma_i^1$  lies at a distance of order  $\lambda^i$  from  $W_{loc}^u$ . Since  $|\lambda||\gamma|$  is less than unity, then  $\lambda^i \ll \gamma^{-i}$ . In the cases of (a),(b), the set  $N$  has the trivial structure:  $N = \{O, \Gamma\}$ . If  $c < 0, d > 0$  (c), then the intersection of  $T_1\sigma_i^1$  with  $\sigma_j^0$  is regular for any  $i, j \geq \bar{k}$ . In this case, the set  $N$  has a nontrivial structure which may be described completely. In the case  $c > 0, d > 0$  (d), any horseshoe  $T_1\sigma_i^1$  is intersected regularly with its “own” strip  $\sigma_i^0$ , with all strips lying above it and with some number (depending on  $i$ ) of strips lying below. The set  $N$  has a nontrivial structure for this case. But, the description of  $N$  depends essentially on parameters of a homoclinic structure (such as the  $\Omega$ -moduli  $\theta$  and  $\tau_0$ ).

**2.2.3. Systems of the third class**

The systems of the third class are those for which  $\lambda > 0, \gamma > 0, c > 0, d > 0$ . In this case,  $T_1W_{loc}^u$  is tangent to  $W_{loc}^s$  from above ( $c > 0, d > 0$ ) (Figure 12d). The study of systems of the third class (and nearby systems) is the main scope of the present paper.

**2.3. Nontrivial Hyperbolic Subsets of Systems of the Third Class**

Taking logarithm of both parts of (2.4), we rewrite the condition of regular intersection as

$$j < i\theta - \tau - S\gamma^{-\bar{k}/2}, \tag{2.8}$$

and the condition of empty intersection as

$$j > i\theta - \tau + S\gamma^{-\bar{k}/2}, \tag{2.9}$$

where

$$\theta = -\frac{\ln|\lambda|}{\ln|\gamma|},$$

$$\tau = \frac{1}{\ln|\gamma|} \ln \left| \frac{cx^+}{y^-} \right|,$$

and  $S$  is some positive constant. It is convenient to rewrite inequalities (2.8) and (2.9) in an “invariant” form

$$(j + m) < (i + m)\theta - \tau_0 - \hat{S}\gamma^{-(\bar{k}+m)/2} \tag{2.10}$$

and

$$(j + m) > (i + m)\theta - \tau_0 + \hat{S}\gamma^{-(\bar{k}+m)/2}, \tag{2.11}$$

respectively, where  $m$  is the constant defined by the condition  $M^+ = f^m(M^-)$  and  $\tau_0$  is defined as

$$\tau_0 = \tau - m(\theta - 1).$$

Note that the value  $\theta$  is independent of smooth transformations of the coordinates. The value  $\tau_0$  can also be proved [9] to be independent of smooth coordinate transformations preserving form (2.1) for the map  $T_0$  as well as of the choice of homoclinic points in  $U_0$ . The number  $(\bar{k} + m)$  is invariant also in that sense that it equals to the minimal period of periodical orbits of  $N$ .

Let us consider the subsystem  $\Omega_1$  (see [6,11]) belonging to  $\Omega_0$  (see Theorem 2) and composed by the orbits of the form

$$(\dots, \alpha_{s-1}, 0, \dots, 0, \alpha_s, 0, \dots, 0, \alpha_{s+1}, \dots),$$

where

- (1)  $\alpha_s \in \{1, 2\}$ ;
- (2) the length of any complete string of zeros is not less than  $(\bar{k} + m)$ ;
- (3) the lengths  $(k_s + m)$  and  $(k_{s+1} + m)$  of successive complete strings of zeros separated by a nonzero symbol satisfy inequality (2.10) with  $i = k_s$  and  $j = k_{s+1}$  (i.e., the sequence  $\{k_s\}$  is regular).

**THEOREM 3.** *If  $\bar{k}$  is large enough, then in the case  $c > 0, d > 0$  there exists a subsystem  $\tilde{N}$  in  $N$  which is conjugate to the symbolic system  $\Omega_1$  and such that all orbits of  $\tilde{N}$  have a saddle-type.*

Note that the set  $\tilde{N}$  may not coincide with  $N$  but it anyway forms a substantial part of  $N$ . Indeed, for a nonsaddle orbit, at least two subsequent points  $M_s$  and  $M_{s+1}$  of intersection with  $\Pi_0$  must lie in the strips  $\sigma_{k_s}^0$  and  $\sigma_{k_{s+1}}^0$  whose numbers satisfy the inequality

$$|(k_{s+1} + m) - (k_s + m)\theta + \tau_0| \leq \hat{S}\gamma^{-(\bar{k}+m)/2}, \tag{2.12}$$

which is equivalent to (2.6).

The set of integer solutions  $(i, j)$  of the last inequality will lie in the narrow strip on the plane (the greater  $\bar{k}$ , the more narrow is the strip). This set depends essentially on the values  $\theta$  and  $\tau_0$ . For instance, if  $\theta$  is rational:  $\theta = p/q$  and  $\tau_0q \notin Z$ , then this set is empty for  $\bar{k}$  large enough. This implies the following statement.

**THEOREM 4.** *If  $\theta = p/q$  and  $\tau_0q \notin Z$ , then there exists such  $\bar{k} = \bar{k}(\theta, \tau_0)$  that all orbits from  $N \setminus \Gamma$  are saddle and  $N \setminus \{\Gamma, O\}$  is conjugate with  $\Omega_1$ .*

Geometrically, the fact that the set of integer solutions of inequality (2.12) is empty for rational  $\theta$  and suitable  $\tau_0$  means that for such  $\theta$  and  $\tau_0$ , tops of all horseshoes get to the “holes” between the strips.

#### 2.4. Moduli of the $\Omega$ -Equivalence for Systems of the Third Class

As we mentioned, the structure of the set  $N$  of all orbits lying in the neighborhood  $U$  entirely is in a close connection with the structure of the sets of integer solutions of inequalities (2.10) and (2.12). These sets are different for different values of the invariants  $\theta$  and  $\tau_0$ . Therefore, the structure of the set  $N$  depends essentially on the values of  $\theta$  and  $\tau_0$ . Moreover, the following result shows that the invariants  $\theta$  and  $\tau_0$  are moduli of the  $\Omega$ -equivalence.

**THEOREM 5.** [9,10] *Let  $f$  and  $f'$  be diffeomorphisms of the third class and let  $f$  and  $f'$  be locally  $\Omega$ -conjugate.<sup>4</sup> Then,  $\theta = \theta'$ . If, moreover, the value  $\theta$  is irrational, then  $\tau_0 = \tau'_0$ . If  $\theta$  is rational ( $\theta = p/q$ ), then there exists such integer  $s$  that  $\tau_0$  and  $\tau'_0$  satisfy simultaneously the inequalities  $s \leq \tau_0 q \leq s + 1$  and  $s \leq \tau'_0 q \leq s + 1$ .*

We give a sketch of the proof of the theorem. Let  $f$  and  $f'$  be locally  $\Omega$ -conjugate and let  $M^+, M^-$  and  $M'^+, M'^-$  be conjugate pairs of homoclinic points. Evidently,  $f^m(M^-) = M^+$  and  $f'^m(M'^-) = M'^+$  for some natural  $m$ . Suppose that  $\theta > \theta'$ . Consider the set of pairs of integers  $(i, j)$  satisfying the inequality

$$(i + m)\theta - \tau_0 - \hat{S}\gamma^{-(\bar{k}+m)/2} > j + m > (i + m)\theta' - \tau'_0 + \hat{S}\gamma^{-(\bar{k}+m)/2}. \tag{2.13}$$

According to conditions (2.10) and (2.11), this inequality means that the pair  $(i, j)$  is regular for the diffeomorphism  $f$ , but it is inadmissible for the diffeomorphism  $f'$ . Since  $\theta > \theta'$ , the set of pairs  $(i, j)$  satisfying condition (2.13) is infinite.

Note that if a pair  $(i, j)$  satisfies condition (2.13), then the pair  $(j, i)$  is also regular for the diffeomorphism  $f$  because here  $j > i$  and the inequality

$$(i + m) < (j + m)\theta - \tau_0 - \hat{S}\gamma^{-(\bar{k}+m)/2},$$

obtained from inequality (2.10) by substitution  $j$  instead of  $i$ , and  $i$  instead of  $j$  is automatically fulfilled (we take into account that  $\theta > 1$  and  $\theta' > 1$ , since we consider the case  $\lambda\gamma < 1$ ).

For such  $i$  and  $j$ , the intersection of the horseshoe  $T_1(\sigma_j^1)$  with the strip  $\sigma_i^0$  and the intersection of the horseshoe  $T_1(\sigma_i^1)$  with the strip  $\sigma_j^0$  are regular (Figure 13a), and the code  $\{\dots ijijij\dots\}$  is regular. By Theorem 3, the diffeomorphism  $f$  has a double-round saddle periodic orbit which intersects successively the strips  $\sigma_i^0$  and  $\sigma_j^0$ .

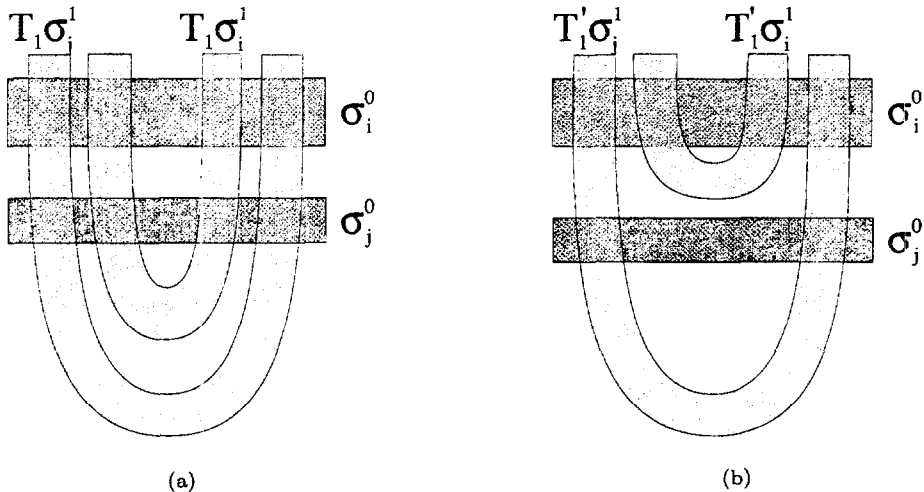

Figure 13. Since  $\theta > \theta'$ , it follows that there exists a countable set of pairs  $(i, j)$  which are regular for the diffeomorphism  $f$ , but they are inadmissible for the diffeomorphism  $f'$ . If  $(i, j)$  is such a pair, then the corresponding strips and horseshoes are positioned as follows. For the diffeomorphism  $f$ : the intersection of the horseshoe  $T_1(\sigma_j^1)$  with the strip  $\sigma_i^0$  is regular as well as the intersection of the horseshoe  $T_1(\sigma_i^1)$  with the strip  $\sigma_j^0$  (a). For the diffeomorphism  $f'$ : the intersection of the horseshoe  $T'_1(\sigma_j^1)$  with the strip  $\sigma_i^0$  is regular, but the horseshoe  $T'_1(\sigma_i^1)$  does not intersect the strip  $\sigma_j^0$  (b).

<sup>4</sup>For example, there exist such neighborhoods  $U$  and  $U'$  for which the sets  $N$  and  $N'$  have the same structure.

On the other hand, for the diffeomorphism  $f'$ , the horseshoe  $T'_1(\sigma_i^1)$  does not intersect the strip  $\sigma_j^0$  (Figure 13b), though  $i$  and  $j$  are the same as above. This follows from the fact that the pair  $(i, j)$  is inadmissible by virtue of the right of inequalities (2.13). Therefore,  $f'$  does not have periodic orbits intersecting successively the strips  $\sigma_i^0$  and  $\sigma_j^0$ . It is clear that the diffeomorphisms  $f$  and  $f'$  are not  $\Omega$ -conjugate in this case. Thus, for the  $\Omega$ -conjugacy it is necessary that  $\theta = \theta'$ .

Now let  $\theta = \theta'$ . Suppose  $\tau'_0 > \tau_0$ . If  $\theta = \theta'$  is irrational, then inequality (2.13) again possesses infinitely many natural solutions for sufficiently large  $\bar{k}$  and the diffeomorphisms  $f$  and  $f'$  are not  $\Omega$ -conjugate. Hence, for the  $\Omega$ -conjugacy of the diffeomorphisms, the equality  $\tau'_0 = \tau_0$  must hold in this case.

Let  $\theta$  be rational,  $\theta = p/q$ . If, for some integer  $s_0$ , inequality  $\tau_0 q > s_0 > \tau'_0 q$  holds, then the integer points on the straight line

$$j = i \frac{p}{q} - \frac{s_0}{q}$$

satisfy inequality (2.13) and the diffeomorphisms  $f$  and  $f'$  are not  $\Omega$ -conjugate again. Hence, for the  $\Omega$ -conjugacy of  $f$  and  $f'$  in this case, it is necessary that  $\tau_0 q, \tau'_0 q \in [s, s + 1]$  for some integer  $s$ , what completes the proof of the theorem.

### 2.5. Infinite Degenerations in Systems of the Third Class

We see that the cases of rational and irrational  $\theta$  are principally different. In the rational case, almost all systems admit a complete description (Theorem 4) and all orbits of  $N \setminus \Gamma$  are saddle. In the irrational case, condition (necessary) (2.12) of an irregular intersection has a countable set of integer solutions for any  $\bar{k}$ . Correspondingly, here a countable number of strips and horseshoes may have irregular intersections which leads to a very nontrivial dynamics. Namely, the following result [7] takes place.

**THEOREM 6.** *If  $H_3$  is a bifurcational surface composed by diffeomorphisms of the third class, then systems with a countable number of saddle periodic orbits each of which has a homoclinic tangency are dense on  $H_3$ .*

The values  $\theta$  calculated for these periodic orbits are  $\Omega$ -moduli, according to Theorem 6. These values are independent of each other. Therefore, we arrive at the following theorem [7].

**THEOREM 7.** *Systems with a countable number of  $\Omega$ -moduli are dense on  $H_3$ .*

As we mentioned in the Introduction, when the value of an  $\Omega$ -modulus is changed, bifurcations of periodic, homoclinic, etc., orbits occur inevitably. The presence of an infinite number of independent  $\Omega$ -moduli may lead to infinitely degenerate bifurcations. Indeed, the following result [7] takes place.

**THEOREM 8.** *Systems with homoclinic tangencies of any order and with structurally unstable periodic orbits of any degree of degeneracy are dense in  $H_3$ .*

It should be noted that the degenerations indicated in this theorem may exist only for periodic and homoclinic orbits of extremely high roundnesses. In the present paper, we will not consider the questions connected with the infinite degeneracies. Further, we will study bifurcations of low-round periodic orbits in the framework of low-parameter families. The control parameters be the splitting parameter as well as the  $\Omega$ -moduli.

First, let us consider the bifurcations of single-round periodic orbits.

### 2.6. Bifurcations of Single-Round Periodic Orbits

Note that for any system belonging to the bifurcational surface  $H_3$ , single-round periodic orbits are structurally stable. Here, for any  $i$  sufficiently large, the horseshoe  $T_1(\sigma_i^1)$  intersects its "own" strip  $\sigma_i^0$  regularly (inequality (2.8) is evidently fulfilled for  $j = i$  due to the condition  $\theta > 1$ ).

Hereat, the structure of the nonwandering set for the map  $T_1T_0^i : \sigma_i^0 \rightarrow \sigma_i^0$  is the same as for the famous Smale's horseshoe example.

However, when the system is perturbed such that the homoclinic tangency is destroyed, the single-round periodic orbits may undergo bifurcations. To study the bifurcations, we imbed the diffeomorphism  $f$  into a one-parameter family  $f_\mu$ , where  $\mu$  is the splitting parameter for the tangency. We assume that when  $\mu < 0$ , the parabola  $T_1W_{loc}^u$  intersects  $W_{loc}^s$  at two points; when  $\mu = 0$ , the parabola  $T_1W_{loc}^u$  is tangent to  $W_{loc}^s$  at one point, and when  $\mu > 0$ , there is no intersection (Figure 14). The family  $f_\mu$  is supposed to depend smoothly on  $\mu$ . The requirement of general position is that the family  $f_\mu$  is transverse to the bifurcational surface  $H_3$  in the space of dynamical systems.

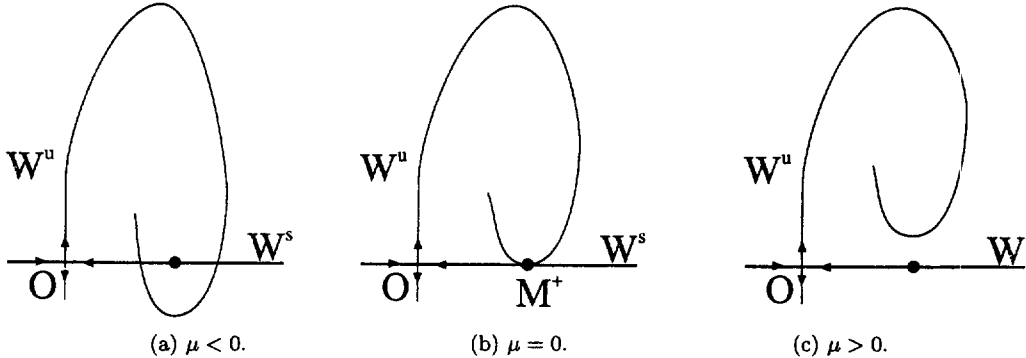

Figure 14. The behavior of  $W^u(O)$  for one-parametric family  $f_\mu$ , where  $\mu$  is the splitting parameter. When  $\mu < 0$ , the parabola  $T_1W_{loc}^u$  intersects  $W_{loc}^s$  at two points; when  $\mu = 0$ , the parabola  $T_1W_{loc}^u$  is tangent to  $W_{loc}^s$  at one point, and when  $\mu > 0$ , there is no intersection.

Clearly, the local and global maps  $T_0$  and  $T_1$  depend now on  $\mu$ . The map  $T_0(\mu)$  can be represented in the form

$$\bar{x} = \lambda x + f(x, y, \mu)x^2y, \quad \bar{y} = \gamma y + g(x, y, \mu)xy^2, \tag{2.14}$$

and the global map  $T_1(\mu)$  is represented in the form

$$\begin{aligned} \bar{x} - x^+ &= ax + b(y - y^-) + \dots, \\ \bar{y} &= cx + d(y - y^-)^2 + \mu + \dots. \end{aligned} \tag{2.15}$$

Below, we will denote the coordinates on  $\Pi_0$  as  $(x_0, y_0)$  and the coordinates on  $\Pi_1$  as  $(x_1, y_1)$ . If  $(x_0, y_0) \in \sigma_k^0$  and  $(x_1, y_1) = T_0^k(x_0, y_0) \in \sigma_k^1$ , the following formula takes place (we change slightly notations in comparison with (2.2)):

$$\begin{aligned} x_1 &= \lambda^k x_0 + |\lambda|^k |\gamma|^{-k} \phi_{k1}(x_0, y_k, \mu), \\ y_0 &= \gamma^{-k} y_1 + |\gamma|^{-2k} \phi_{k2}(x_0, y_k, \mu). \end{aligned} \tag{2.16}$$

It is clear that if the bottom of the parabola  $T_1W_{loc}^u$  descends sufficiently low (large and negative  $\mu$ ), then each horseshoe intersects each strip. In this case, the set  $N_\mu$  is a hyperbolic set similar to the invariant set in the Smale horseshoe. However, if  $\mu$  is sufficiently large and positive, then the horseshoes and the strips do not intersect at all, and all of the orbits except  $O$  will escape from  $U$ .

The main question is what happens when the parameter  $\mu$  varies from the negative to the positive values. First of all, it is necessary to study the structure of the bifurcation set corresponding to one strip, that is, to study the bifurcations in the family of the first return maps



$T_k(\mu) \equiv T_1 T_0^k : \sigma_k^0 \rightarrow \sigma_k^0$ . The following result (see [13]) makes the analysis of the map  $T_k$  very simple.

LEMMA 2.1. *By means of a transformation of the coordinates and the parameter, the map  $T_k(\mu)$  can be brought to the form*

$$\begin{aligned} \bar{x} &= y + \varepsilon_{1k}(x, y, \mu), \\ \bar{y} &= M - y^2 + \varepsilon_{2k}(x, y, \mu), \end{aligned} \tag{2.17}$$

where

$$\varepsilon_{ik}(x, y, \mu) = O(\lambda^k \gamma^k + \gamma^{-k}). \tag{2.18}$$

Here the rescaled splitting parameter  $M = -d\gamma^{2k}(\mu - \gamma^{-k}y^- + c\lambda^k x^+ \dots)$  may take arbitrary finite values for sufficiently large  $k$ .

PROOF. It is convenient to use the pair  $(x_0, y_1)$  as the coordinates for points on  $\sigma_k^0$ . We can use the coordinate  $y_1$  instead of  $y_0$  because the value  $y_0$  is determined uniquely by formula (2.16) as a function of  $(x_0, y_1)$  for a fixed  $k$ . By virtue of equations (2.16), (2.15), the map  $T_k(\mu)$  is written in the form

$$\begin{aligned} \bar{x}_0 - x^+ &= a\lambda^k x_0(1 + \dots) + b(y_1 - y^-) + \dots, \\ \gamma^{-k}\bar{y}_1(1 + \gamma^{-k}\eta_k(\bar{x}_0, \bar{y}_1)) &= \mu + c\lambda^k x_0(1 + \dots) + d(y_1 - y^-)^2 + \dots. \end{aligned} \tag{2.19}$$

With the shift of the origin:  $y_1 \rightarrow y + y^-$ ,  $x_0 \rightarrow x + x^+$ , we write the map  $T_k(\mu)$  in the form

$$\begin{aligned} \bar{x} &= by + O(\lambda^k) + O(y^2), \\ \gamma^{-k}\bar{y} + \gamma^{-2k}O(\bar{y}) &= M_1 + dy^2 + \lambda^k O(|x| + |y|) + O(y^3), \end{aligned} \tag{2.20}$$

where

$$M_1 = \mu + c\lambda^k x^+ - \gamma^{-k}y^- + \dots. \tag{2.21}$$

Now, rescaling the variables

$$x \rightarrow -\frac{b}{d}\gamma^{-k}x, \quad y \rightarrow -\frac{1}{d}\gamma^{-k}y$$

brings equations (2.20) to form (2.17), where  $M = -d\gamma^{2k}M_1$ . This completes the proof of the lemma.

Map (2.17) is close to the one-dimensional parabola map

$$\bar{y} = M - y^2, \tag{2.22}$$

whose bifurcations have been well studied, so that it is possible to recover the bifurcation picture for the initial map  $T_k$ . For the parabola map, the bifurcation set is contained in the interval  $[-(1/4), 2]$  of values of  $M$ : at  $M = -(1/4)$ , there appears a fixed point with the multiplier equal to  $+1$ , this fixed point is attractive at  $M \in (-(1/4), 3/4)$  and it undergoes a period-doubling bifurcation at  $M = 3/4$ ; the cascade of period-doubling bifurcations lead to chaotic dynamics which alternates with stability windows and the bifurcations stop at  $M = 2$ , when the restriction of the map onto the nonwandering set becomes conjugate to the Bernoulli shift of two symbols and the map no longer bifurcates as  $M$  increases.

By Lemma 2.1, similar bifurcations take place for the map  $T_k$ . The map has an attractive fixed point  $O_k$  at  $\mu \in (\mu_k^{+1}, \mu_k^{-1})$  which arises at the saddle-node bifurcation at  $\mu = \mu_k^{+1}$  and loses stability at  $\mu = \mu_k^{-1}$  at the period-doubling bifurcation. Here,

$$\begin{aligned} \mu_k^{+1} &= \gamma^{-k}y^- - c\lambda^k x^+ + \frac{1}{4d}\gamma^{-2k} + \dots, \\ \mu_k^{-1} &= \gamma^{-k}y^- - c\lambda^k x^+ - \frac{3}{4d}\gamma^{-2k} + \dots. \end{aligned}$$

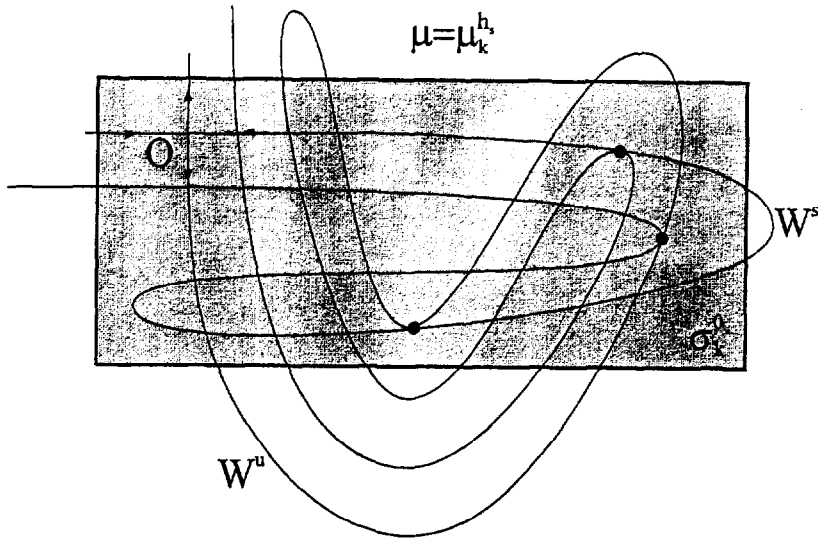

Figure 15. The last homoclinic tangency of the manifolds of the fixed point of  $T_k$  at  $\mu = \mu_k^{hs}$ . An invariant set similar to those of the Smale's horseshoe example arises after this bifurcation.

The bifurcation set of the map  $T_k$  is contained in the interval  $[\mu_k^{+1}, \mu_k^{hs}]$ , where

$$\mu_k^{hs} = \gamma^{-k} y^- - c\lambda^k x^+ - \frac{2}{d} \gamma^{-2k} + \dots$$

At  $\mu = \mu_k^{hs}$ , the fixed point of  $T_k$  has the last homoclinic tangency (Figure 15) and an invariant set similar to those of the Smale's horseshoe example arises after this bifurcation. Note that these bifurcational intervals do not intersect each other for different  $k$ .

### 2.7. Bifurcations of Double-Round Periodic Orbits

The study of double-round periodic orbits is reduced to the study of the fixed points of the second return maps  $T_{ij} = T_1 T_0^i T_1 T_0^j: \Pi_0 \rightarrow \Pi_0$ , which by virtue of equations (2.16), (2.15), are represented in the form

$$\begin{aligned} \bar{x}_0 - x^+ &= a\lambda^j x_0 + b(y_1 - y^-) + \dots, \\ \gamma^{-i} \bar{y}_1 (1 + \dots) &= c\lambda^j x_0 + d(y_1 - y^-)^2 + \mu + \dots, \\ \bar{\bar{x}}_0 - x^+ &= a\lambda^i \bar{x}_0 + b(\bar{y}_1 - y^-) + \dots, \\ \gamma^{-j} \bar{\bar{y}}_1 (1 + \dots) &= c\lambda^i \bar{x}_0 + d(\bar{y}_1 - y^-)^2 + \mu + \dots, \end{aligned} \tag{2.23}$$

where  $(x_0, y_1)$  and  $(\bar{\bar{x}}_0, \bar{\bar{y}}_1)$  are the coordinates on the strip  $\sigma_j^0$  for an initial point and its image by the map  $T_{ij}$ , respectively, and  $(\bar{x}_0, \bar{y}_1)$  are the coordinates for the intermediate point  $T_1 T_0^j(x_0, y_1)$  on the strip  $\sigma_i^0$ .

The map  $T_{ij}$  is a composition of the successively acting maps  $T_j \equiv T_1 T_0^j$  and  $T_i \equiv T_1 T_0^i$ , which are defined, respectively, on the strips  $\sigma_j^0$  and  $\sigma_i^0$ . The map  $T_i$  transforms the strip  $\sigma_i^0$  into the horseshoe  $T_1 \sigma_i^1$ , and the map  $T_j$  transforms the strip  $\sigma_j^0$  into the horseshoe  $T_1 \sigma_j^1$ .

#### 2.7.1. Bifurcations on $H_3$

Let us consider here the case  $\mu = 0$ . Different cases of the reciprocal position of the strips and horseshoes  $\sigma_i^0, \sigma_j^0, T_1 \sigma_i^1, T_1 \sigma_j^1$  are shown in Figures 16a–16c. We assume here  $j > i$  (we do not consider the case  $i = j$ ). The horseshoe  $T_1 \sigma_j^1$  intersects both strips  $\sigma_i^0$  and  $\sigma_j^0$  regularly, and the horseshoe  $T_1 \sigma_i^1$  intersects regularly the strip  $\sigma_i^0$ . For the intersection of  $T_1 \sigma_i^1 \cap \sigma_j^0$ , different

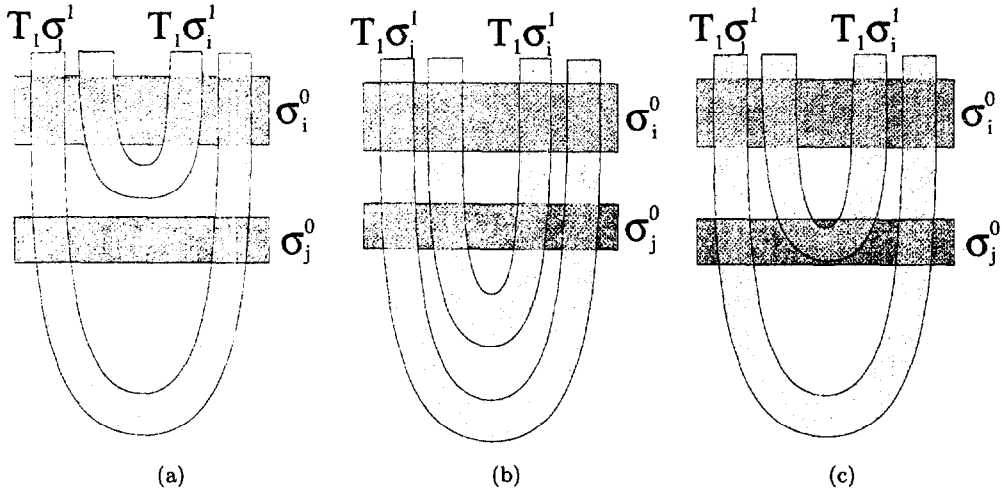

Figure 16. The various cases of the reciprocal position of the strips and horseshoes  $\sigma_i^0, \sigma_j^0, T_1\sigma_i^1, T_1\sigma_j^1$  are shown for the case  $\mu = 0$ .

possibilities may take place:  $T_1\sigma_i^1 \cap \sigma_j^0 = \emptyset$  in the case of Figure 16a; the intersection of  $T_1\sigma_i^1$  with  $\sigma_j^0$  is regular in the case of Figure 16b, and irregular in the case of Figure 16c.

The conditions of the regular, irregular, and empty intersection of the corresponding strips and horseshoes are written by the use of inequalities (2.8),(2.9). Note that since we are interested now by the bifurcations of the double-round periodic orbits which do not intersect  $\Pi^0$  above the strip  $\sigma_i^0$ , we may assume  $i = \bar{k}$  in these inequalities.

If  $T_1\sigma_i^1 \cap \sigma_j^0 = \emptyset$ , then the map  $T_{ij}$  has no fixed points. In this case,  $i$  and  $j$  satisfy the inequality

$$j - i\theta + \tau > S\gamma^{-i/2}. \tag{2.24}$$

On the other hand, if  $i$  and  $j$  satisfy the inequality

$$j - i\theta + \tau < -S\gamma^{-i/2}, \tag{2.25}$$

the intersection of  $T_1\sigma_i^1$  with  $\sigma_j^0$  is regular, and the map  $T_{ij}$  has saddle fixed points: there are exactly four such points, two of them have positive multipliers, and two have negative multipliers.<sup>5</sup>

It is clear that if one changes the system on  $H_3$  so that to come from the situation of Figure 16a to the situation of Figure 16b, then bifurcations connected with the appearance of fixed points of  $T_{ij}$  (double-round periodic orbits  $f$ ) will occur on the way.

To follow these bifurcations, it is convenient to consider one-parameter families of systems on  $H_3$ , where the invariant  $\theta$  is the control parameter (note that when proving Theorem 5, which establishes that  $\theta$  is an  $\Omega$ -modulus for the systems on  $H_3$ , we just used the fact that the variation of  $\theta$  is connected with the changes in the structure of intersections of the strip and horseshoes).

Let  $f_\theta$  be such a family. Let  $i$  and  $j$  be sufficiently large fixed integers. By virtue of (2.24), if

$$\theta < \theta_1 \equiv \frac{j}{i} + \frac{1}{i}\tau - \frac{1}{i}S\gamma^{-i/2}, \tag{2.26}$$

then  $T_1\sigma_i^1 \cap \sigma_j^0 = \emptyset$  and the map  $T_{ij}$  does not have fixed points. When  $\theta$  increases, the bottom of the horseshoe  $T_1\sigma_i^1$  moves down, and for the values of  $\theta$  such that

$$\theta > \theta_2 \equiv \frac{j}{i} + \frac{1}{i}\tau + \frac{1}{i}S\gamma^{-i/2}, \tag{2.27}$$

<sup>5</sup>Moreover, Theorem 3 implies that the nonwandering set of the map  $T_{ij}$  is nontrivial in this case and has a hyperbolic structure.

the intersection of  $T_1\sigma_i^1$  with  $\sigma_j^0$  will be regular, and the map  $T_{ij}$  will have four saddle fixed points.

We, therefore, get that all bifurcations of the double-round periodic orbits which intersect the strips  $\sigma_i^0$  and  $\sigma_j^0$  occur for the values of  $\theta$  belonging to the interval

$$\frac{j}{i} + \frac{1}{i}\tau - \frac{1}{i}S\gamma^{-i/2} \equiv \theta_1 \leq \theta \leq \theta_2 \equiv \frac{j}{i} + \frac{1}{i}\tau + \frac{1}{i}S\gamma^{-i/2}. \tag{2.28}$$

To clarify how the bifurcations go, we give a more detailed geometric construction (see Figure 17). The horseshoe  $T_1\sigma_j^1$  intersects the strip  $\sigma_i^0$  in two connected components which are denoted as  $\tilde{\Delta}_{ij}^1$  and  $\tilde{\Delta}_{ij}^2$ . The preimages of these components with respect to the map  $T_j$  are the two “substrips”  $\Delta_{ij}^1$  and  $\Delta_{ij}^2$  lying on  $\sigma_j^0$  (so,  $T_j(\tilde{\Delta}_{ij}^\alpha) = \Delta_{ij}^\alpha$ ,  $\alpha = 1, 2$ ). The image of the strip  $\Delta_{ij}^\alpha$  with respect to the map  $T_{ij}$  is a thin horseshoe  $T_{ij}(\Delta_{ij}^\alpha)$  lying in  $T_1\sigma_i^1$ .

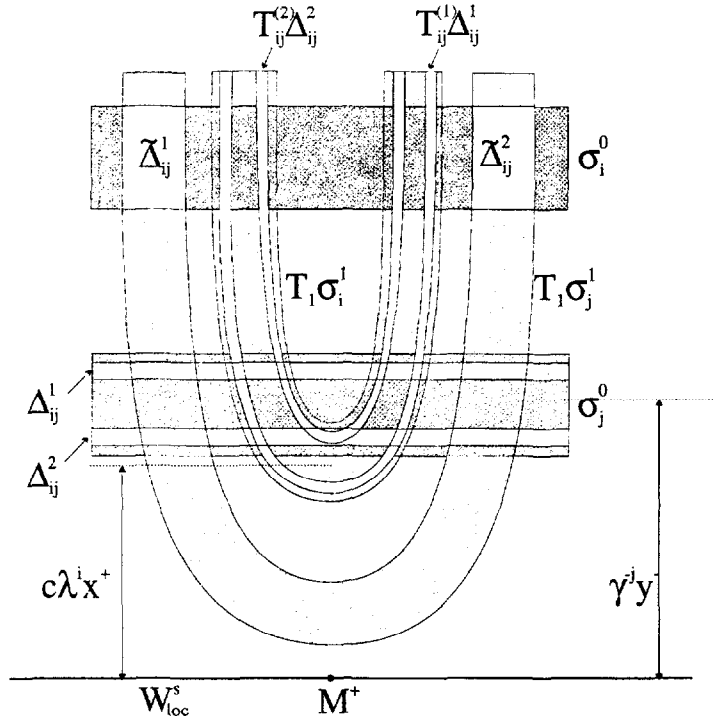

Figure 17. Details of the geometric structure for the bihorseshoe composed by the strips and horseshoes  $\sigma_i^0$ ,  $\sigma_j^0$ ,  $T_1\sigma_i^1$ ,  $T_1\sigma_j^1$ . The horseshoe  $T_1\sigma_j^1$  intersects the strip  $\sigma_i^0$  on two connected components  $\tilde{\Delta}_{ij}^1$  and  $\tilde{\Delta}_{ij}^2$ . Two “substrips”  $\Delta_{ij}^1$  and  $\Delta_{ij}^2$  in  $\sigma_j^0$  are the preimages of these components; i.e.,  $T_j(\tilde{\Delta}_{ij}^\alpha) = \Delta_{ij}^\alpha$ ,  $\alpha = 1, 2$ . The image of the strip  $\Delta_{ij}^\alpha$  under the map  $T_{ij}$  is the narrow horseshoe  $T_{ij}(\Delta_{ij}^\alpha)$  belonging to  $T_1\sigma_i^1$ .

The dynamics of the map  $T_{ij} : \sigma_j^0 \rightarrow \sigma_i^0$  is determined by that how it acts in restriction onto the substrips  $\Delta_{ij}^1$  and  $\Delta_{ij}^2$ . Particularly, the fixed points of  $T_{ij}$  are divided into two groups: the first are the fixed points of the map  $T_{ij}^{(1)} = T_{ij}|_{\Delta_{ij}^1}$ , and the second are the fixed points of the map  $T_{ij}^{(2)} = T_{ij}|_{\Delta_{ij}^2}$ . Since the regions  $\Delta_{ij}^1$  and  $\Delta_{ij}^2$  do not intersect for all  $\theta$ , the fixed points of each of the maps bifurcate independently.

It can be shown (see [8]) that exactly two bifurcations take place in each group when  $\theta$  varies; namely, a pair of saddle and stable fixed points of  $T_{ij}^{(\alpha)}$  appears at  $\theta_{ij}^{\alpha+}$  through the saddle-node bifurcation corresponding to the presence of a multiplier equal to “+1,” and the stable fixed point loses its stability at  $\theta_{ij}^{\alpha-}$  through the period-doubling bifurcation corresponding to the presence of a multiplier equal to “-1.” The following asymptotic takes place:

$$\theta_{ij}^{\alpha\pm} = \frac{j}{i} + \frac{\tau}{i} + (-1)^\alpha \frac{1}{i} \frac{1 - by^-/x^+}{y^- \ln \gamma} \sqrt{\frac{y^-}{d}} \gamma^{-i/2} + \dots, \tag{2.29}$$

where  $\alpha = 1$  is assumed to correspond to the upper of the substrips  $\Delta_{ij}$  and  $\alpha = 2$  to the lower one (Figure 17). Note that the asymptotics for the moments corresponding to the “+1” and “-1” bifurcations coincide in the main order. Nevertheless, the intervals

$$\delta_{ij\alpha} = (\theta_{ij}^{\alpha+}, \theta_{ij}^{\alpha-})$$

are, evidently, nonempty and they correspond to the presence of a stable double-round periodic orbit.

**2.7.2. Systems on  $H_3$  with infinitely many stable periodic orbits**

Since  $\sigma = |\lambda\gamma| < 1$ , it follows that the Jacobian of the map  $T_{ij}$  equal to  $(bc)^2(\lambda\gamma)^{i+j}(1 + \dots)$  is less than unity if  $i$  and  $j$  are sufficiently large. Thus, the saddle-node bifurcations of double-round periodic orbits lead to the appearance of the stable periodic orbits indeed.

The following assertion was established in [8,14].

**PROPOSITION 2.2.** *Let  $f_\theta$  be a one-parameter family of systems on  $H_3$ . Then, in the interval  $\theta > 1$ , the values  $\theta^*$  are dense such that the diffeomorphism  $f_{\theta^*}$  possesses infinitely many stable double-round periodic orbits.*

This result follows from the fact that the stability regions  $\delta_{ij\alpha}$  may intersect for different  $(i, j)$ . Indeed, as it follows from (2.29), the map  $T_{ij}^\alpha$  has a stable fixed point if

$$\nu_{ij}^1 < j - \theta i + \tau - \nu_0 \gamma^{-i/2} < \nu_{ij}^2, \tag{2.30}$$

where  $\nu_{ij}^1 < \nu_{ij}^2$ ,  $\nu_{ij}^{1,2} = o(\gamma^{-i/2})$  and  $\nu_0$  does not depend on  $i$  and  $j$ .

In order for an infinite number of stable double-round periodic orbits to exist for the diffeomorphism  $f_\theta$ , it is necessary and sufficient that inequality (2.30) would have infinitely many integer solutions  $(i, j)$ . The standard fact from the number theory is that for any functions  $\nu_{ij}^{1,2}$  tending to zero as  $i, j \rightarrow +\infty$  such inequality do have infinitely many integer solutions for a dense set of values of  $\theta$ .

Note that inequality (2.30) is satisfied only if the invariants  $\theta$  and  $\tau$  admit “exponentially well” nonhomogeneous approximations by rational fractions.

**2.7.3. Bifurcations in the case  $\mu \neq 0$**

Let us now consider bifurcations of double-round periodic orbits for the diffeomorphisms which are close to  $f$  and which may now not lie on  $H_3$ .

First, consider a one-parameter family  $f_\mu$ . Recall that the absolute value of the splitting parameter  $\mu$  is exactly the distance between the bottom of the parabola  $T_1(W_{loc}^u)$  and the manifold  $W_{loc}^s$ . The sign of  $\mu$  corresponds to where the bottom of the parabola lies: above or below  $W_{loc}^s$ . If  $\mu > 0$ , the diffeomorphism  $f_\mu$  does not have single-round homoclinic orbits close to  $\Gamma$ , and when  $\mu < 0$ , the diffeomorphism has two such orbits.

When  $\mu$  increases, the bottom of the parabola  $T_1(W_{loc}^u)$  will move up and when  $\mu$  decreases, it will move down. Accordingly, the bottoms of all horseshoes will move up and down. It follows from equations (2.14),(2.15) that the bottom of the horseshoe  $T_1\sigma_i^1$  lies on a distance of the order

$$\mu + c\lambda^i x^+ \tag{2.31}$$

from the manifold  $W_{loc}^s$ . Recall also that the strip  $\sigma_j^0$  lies on a distance of the order

$$\gamma^{-j} y^- \tag{2.32}$$

from the manifold  $W_{loc}^s$ .

Take some  $i$  and  $j$  such that, for  $\mu = 0$ , the horseshoe  $T_1\sigma_i^1$  does not intersect the strip  $\sigma_j^0$  (Figure 16a). Evidently, there is infinitely many such pairs  $(i, j)$ . Since, for  $\mu = 0$ , the horseshoe  $T_1\sigma_i^1$  lies above the strip  $\sigma_j^0$  (i.e.,  $c\lambda^i x^+ > \gamma^{-j} y^-$ ), we have by virtue of (2.31),(2.32), that it lies above this strip for all positive  $\mu$ . Therefore, for the given  $i$  and  $j$ , the map  $T_{ij}$  does not undergo bifurcations for positive  $\mu$ . However, when  $\mu$  is negative, the horseshoe  $T_1\sigma_i^1$  may have a nonempty intersection with the strip  $\sigma_j^0$  (this intersection will be nonempty and regular for sufficiently large negative  $\mu$ ). Thus, it is clear that there exists  $\mu = \mu_{ij}^* < 0$  for which the map  $T_{ij}$  has a structurally unstable fixed point. Evidently,  $\mu_{ij}^* \rightarrow 0$  as  $i, j \rightarrow \infty$ .

Take another pair of  $i$  and  $j$  such that, for  $\mu = 0$ , the horseshoe  $T_1\sigma_i^1$  has a regular intersection with the strip  $\sigma_j^0$  (Figure 16b); the set of such pairs is also infinite. Note that, for the given  $i$  and  $j$ , the horseshoe  $T_1\sigma_i^1$  has regular intersection with the strip  $\sigma_j^0$  for all negative  $\mu$ . Therefore, in this case, the map  $T_{ij}$  does not undergo bifurcations for negative  $\mu$ . On the other hand, if  $\mu$  is positive, the horseshoe  $T_1\sigma_i^1$  may have empty intersection with the strip  $\sigma_j^0$  (if  $\mu + c\lambda^i x^+ > \gamma^{-j} y^-$ ; see (2.31),(2.32)). It is clear, therefore, that there exists  $\mu = \tilde{\mu}_{ij}^* > 0$  for which the map  $T_{ij}$  has a structurally unstable fixed point. Note also that  $\tilde{\mu}_{ij}^* \rightarrow 0$  as  $i, j \rightarrow \infty$ .

We arrive at the following statement [6].

**PROPOSITION 2.3.** *There exists an infinite number of values of  $\mu$  accumulating at  $\mu = 0$  from both sides which correspond to the presence of the structurally unstable double-round periodic orbits.*

If, similar to the case  $\mu = 0$ , consider the substrips  $\Delta_{ij}^1(\mu)$ ,  $\Delta_{ij}^2(\mu)$  and the corresponding horseshoes  $T_{ij}(\mu)\Delta_{ij}^1$  and  $T_{ij}(\mu)\Delta_{ij}^2$ , then repeating the arguments of [8], one can show that the following asymptotics take place for the bifurcational values of  $\mu$ :

$$\mu_{ij}^{\alpha\pm} = \gamma^{-j} y^- - c\lambda^i x^+ + (-1)^\alpha \gamma^{-i/2} \lambda^i \frac{cx^+}{y^-} \sqrt{\frac{y^-}{d}} \left( 1 - \frac{by^-}{x^+} \right) (1 + \dots), \quad \alpha = 1, 2. \quad (2.33)$$

Here  $\alpha = 1$  corresponds to the bifurcations of the fixed points of the map  $T_{ij}(\mu)|_{\Delta_{ij}^1}$ , and  $\alpha = 2$  corresponds to the bifurcations of the fixed points of the map  $T_{ij}(\mu)|_{\Delta_{ij}^2}$ . The signs  $\pm$  in the left-hand side of formula (2.33) denote the bifurcation moments corresponding to the multiplier equal to “+1” or to “-1”, respectively.

Note that these bifurcation moments differ on a small value of order  $o(\gamma^{-i/2})$ . In spite of the intervals  $\tilde{\delta}_{ij} = (\mu_{ij}^{\alpha-}, \mu_{ij}^{\alpha+})$  of existence of a stable double-round periodic orbit are extremely small, they, nevertheless, may intersect each other (which is not the case for the analogous intervals corresponding to single-round orbits; see above), and even an infinite number of these intervals may intersect. We have already seen this in the previous section, when proved that the value  $\mu = 0$  belongs to the intersection of infinitely many regions of existence and stability of double-round periodic orbits if  $\theta$  and  $\tau$  admits exponentially well nonhomogeneous approximations by rational fractions.

The structure of these intersections cannot be studied in a one-parameter family  $f_\mu$  because it depends essentially on, for instance, the values of  $\theta$  and  $\tau$ . Indeed, as we have shown, the structure of the set of the values of  $\mu$  corresponding to the bifurcations of double-round periodic orbits of  $f_\mu$  depends essentially on the reciprocal position of the strips and horseshoes for the diffeomorphism  $f_0$ . The latter is mainly determined by the values of  $\theta$  and  $\tau$ . If, for instance,  $\theta > \theta'$ , then there would exist infinitely many pairs  $(i, j)$  such that, for the diffeomorphism  $f_0$ , the horseshoe  $T_1\sigma_i^1$  have regular intersection with the strip  $\sigma_j^0$ , and the horseshoe  $T_1'\sigma_i^1$  has no intersection with the strip  $\sigma_j^0$  for the diffeomorphism  $f_0'$  (see Theorem 5). Therefore, for the family  $f_\mu$ , bifurcations of the double-round periodic orbits corresponding to the given values of  $i$  and  $j$  would happen at positive  $\mu$ , and for the family  $f'_\mu$ , they would happen at negative  $\mu$ . In other words, an arbitrary variation of  $\theta$  changes the order of “double-round” bifurcations in the family  $f_\mu$ .

In fact, using the machinery of “infinite degenerations” from [7], one can show that, by an arbitrary small perturbation of the family  $f_\mu$  in the space of one-parameter families of dynamical systems, a family can be obtained for which values of  $\mu$  accumulates at  $\mu = 0$  corresponding to infinitely many coexisting structurally unstable double-round periodic orbits.

This implies that no finite number of control parameters is sufficient to obtain a stable picture of the bifurcation set corresponding to all double-round periodic orbits. At the same time, we have seen that if we restrict ourself to the study of the bifurcations of one double-round periodic orbit corresponding to an arbitrary code  $\{i, j\}$ , the one-parameter bifurcation analysis is quite satisfactory: there is a value of  $\mu$  corresponding to the saddle-node bifurcation and a value of  $\mu$  corresponding to the period-doubling bifurcation and no other bifurcation values.

## 2.8. Bifurcations of Triple-Round Periodic Orbits. Cusp-Bifurcations

### 2.8.1. Bifurcations on $H_3$

In this section, we consider the bifurcations of triple-round periodic orbits. In particular, we show that, in distinction with the single- and double-round periodic orbits, structurally unstable triple-round periodic orbits can have additional degenerations; namely, the first Lyapunov value may vanish. This means that *cusp-bifurcations* take place here.

This fact was established in [15] at the study of two-parameter families of systems on  $H_3$  for which the  $\Omega$ -moduli  $\theta$  and  $\tau$  are taken as the control parameters.

Let  $f_{\theta, \tau}$  be a two-parameter family in  $H_3$ . Then, the following result holds.

**THEOREM 9.** *The values of  $(\theta, \tau)$  for which the system has a structurally unstable triple-round periodic orbit with one multiplier equal to unity and with first Lyapunov value equal to zero are dense in the region  $\tilde{L} = \{(\theta, \tau) : \theta > 1\}$  on the parameter plane.<sup>6</sup>*

**PROOF.** The study of triple-round periodic orbits is reduced to the study of the fixed points of the third-return maps  $T_{ijk} \equiv T_1 T_0^k T_1 T_0^j T_1 T_0^i: \sigma_i^0 \rightarrow \sigma_i^0$ . We will suppose  $i < j < k$  (this condition can be shown to be necessary for the existence of the cusp-bifurcation).

The analysis carried out in [1] shows that the additional degeneration may take place only for the following structure of the intersections of the corresponding horseshoes and strips (Figure 18): the horseshoe  $T_1 \sigma_i^1$  intersects the strip  $\sigma_i^0$  regularly and intersects the strip  $\sigma_j^0$  irregularly, the horseshoe  $T_1 \sigma_j^1$  intersects the strips  $\sigma_i^0, \sigma_j^0$  regularly and intersects the strip  $\sigma_k^0$  irregularly, the horseshoe  $T_1 \sigma_k^1$  intersects all the strips regularly.

The study of triple-round periodic orbits is obviously reduced to the study of a system of equations connected the coordinates  $(x_0, y_0)$  and  $(x_1, y_1)$  of the points of intersection of the orbit with the neighborhoods  $\Pi_0$  and  $\Pi_1$ , respectively. We do not write down the system here. Note that the system is easily resolved with respect to the coordinates  $x_0, y_0$ , and  $x_1$ . If  $\{ijk\}$  is the code of the periodic orbit under consideration, then the system takes the form [6]

$$\begin{aligned} \gamma^{-j} \eta &= d\xi^2 + (cx^+ \lambda^i - \gamma^{-j} y^-) + bc\lambda^i \zeta + \dots, \\ \gamma^{-k} \zeta &= d\eta^2 + (cx^+ \lambda^j - \gamma^{-k} y^-) + bc\lambda^j \xi + \dots, \\ \gamma^{-i} \eta &= d\zeta^2 + (cx^+ \lambda^k - \gamma^{-i} y^-) + bc\lambda^k \eta + \dots, \end{aligned} \tag{2.34}$$

where we denote the value  $y_1 - y^-$  as  $\xi$  for the point of intersection of the orbit with the strip  $\sigma_i^1$ , as  $\eta$  for the point of intersection with the strip  $\sigma_j^1$ , and as  $\zeta$  for the point of intersection with the strip  $\sigma_k^1$ . The degenerate periodic orbits (i.e., having one multiplier equal to unity) correspond to the degenerate solutions of system (2.34).

<sup>6</sup>Note that the second Lyapunov value does not equal to zero here [15], so these points are the cusp-points from which a pair of curves corresponding to saddle-node bifurcations go.

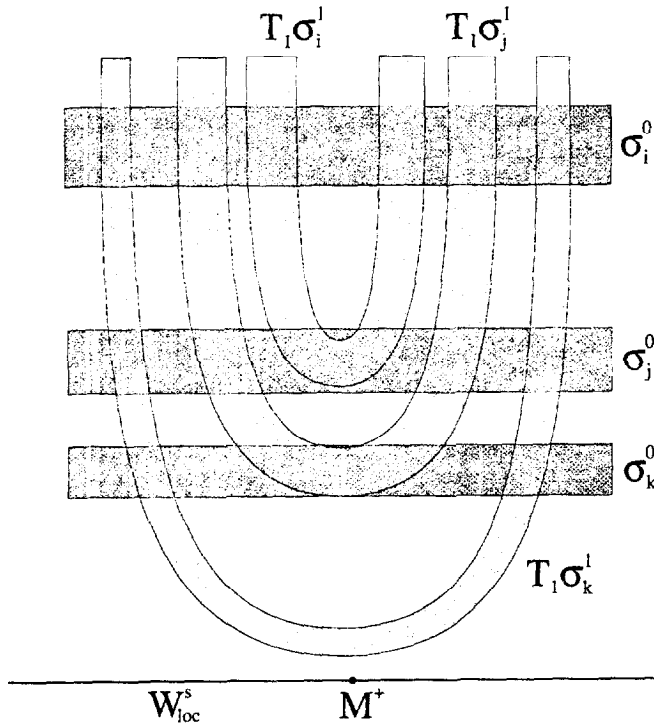

Figure 18. The geometric construction leading to the appearance of doubly-degenerate triple-round periodic orbits (the cusp-bifurcation). The horseshoe  $T_1\sigma_i^1$  intersects the strip  $\sigma_i^0$  regularly and it intersects the strip  $\sigma_j^0$  irregularly; the horseshoe  $T_1\sigma_j^1$  intersects the strips  $\sigma_i^0$ ,  $\sigma_j^0$  regularly and it intersects the strip  $\sigma_k^0$  irregularly; the horseshoe  $T_1\sigma_k^1$  intersects regularly all the strips.

Since  $i < k$  and  $\lambda\gamma < 1$ , the last equation of system (2.34) is resolved with respect to  $\zeta$ :

$$\zeta = \pm \sqrt{\frac{y^-}{d}} \gamma^{-i/2} (1 + \dots). \tag{2.35}$$

The substitution of expression (2.35) in the first and second equations of system (2.34) and a shift of coordinates  $\xi$  and  $\eta$  on some small constants bring the system to the form

$$\begin{aligned} \gamma^{-j}\eta &= d\xi^2 + (cx^+\lambda^i - \gamma^{-j}y^-) + \dots, \\ -bc\lambda^j\xi &= d\eta^2 + (cx^+\lambda^j - \gamma^{-k}y^-) + \dots. \end{aligned} \tag{2.36}$$

Thus, the question about the degenerate triple-round periodic orbits is reduced to the question about the degenerate solutions of the system (2.36) corresponding to large  $i, j, k$ , and to small  $\xi$  and  $\eta$ .

Let us show that the system has a triple solution. Make the following rescaling of the variables:  $\xi = \epsilon_1 \cdot u$ ;  $\eta = \epsilon_2 \cdot v$ , where

$$\epsilon_1 = -\frac{(bc)^{1/3}}{d} \cdot \lambda^{j/3} \cdot \gamma^{-2j/3}, \quad \epsilon_2 = \frac{(bc)^{2/3}}{d} \cdot \lambda^{2j/3} \cdot \gamma^{-j/3}.$$

Dividing the first and second equations of (2.36) on  $d \cdot \epsilon_1^2$  and  $d \cdot \epsilon_2^2$ , respectively, we arrive at the following system:

$$\begin{aligned} u^2 &= v + A + \delta_1(u, v), \\ v^2 &= u + B + \delta_2(u, v), \end{aligned} \tag{2.37}$$

where  $\delta_{1,2} \rightarrow 0$  as  $i, j, k \rightarrow +\infty$  and the quantities  $A$  and  $B$  are as follows:

$$\begin{aligned} A &= \frac{d}{(bc)^{2/3}} \lambda^{-2j/3} \gamma^{4j/3} [y^- \gamma^{-j} - cx^+ \lambda^i + \dots], \\ B &= \frac{d}{(bc)^{4/3}} \lambda^{-4j/3} \gamma^{2j/3} [y^- \gamma^{-k} - cx^+ \lambda^j + \dots]. \end{aligned} \tag{2.38}$$

Evidently,  $A$  and  $B$  may take arbitrary finite values if  $i$  and  $j$  are sufficiently large.



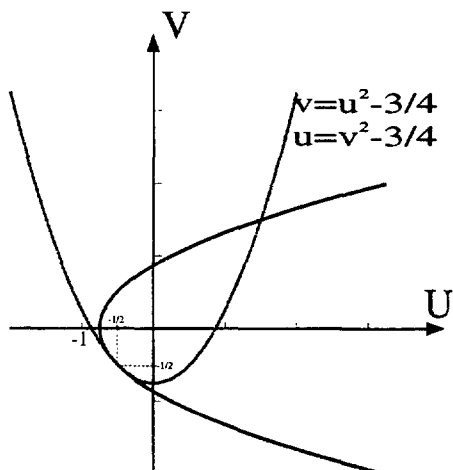

Figure 19. The case of the cubic tangency of two parabolas.

It is easy to see that the triple solution of system (2.37) exists when  $A \approx 3/4$ ,  $B \approx 3/4$ . The geometric illustration of this fact is represented in Figure 19.

We obtained a necessary and sufficient condition for existence of triple solution of system (2.34). This condition can be rewritten as

$$\begin{aligned} y^- \gamma^{-j} - cx^+ \lambda^i + \dots &= 0, \\ y^- \gamma^{-k} - cx^+ \lambda^j + \dots &= 0. \end{aligned} \tag{2.39}$$

Taking the logarithm of the both parts of each of the equations of the system obtained we arrive at the equivalent system

$$\begin{aligned} j &= \theta i - \tau + \dots, \\ k &= \theta j - \tau + \dots. \end{aligned} \tag{2.40}$$

This system can be shown to have arbitrarily large integer solutions for a dense set of values of the parameters  $(\theta, \tau)$ . So we can conclude that there exists a dense set  $L^*$  on the parameter plane such that for any pair  $(\theta^*, \tau^*) \in L^*$ , there exists a triple solution of system (2.34) for some  $i, j, k$ . This means that the dynamical system has an associated structurally-unstable triple-round periodic orbit arising as the result of the coalescence of three periodic orbits. Such orbit has a multiplier equal to unity and the first Lyapunov value is equal to zero. The theorem is proved.

Let us now construct the bifurcational curves, starting at the cusp points, which correspond to saddle-node triple-round periodic orbits. Let  $\alpha = A - 3/4$  and  $\beta = B - 3/4$ . System (2.37) takes the form

$$\begin{aligned} u^2 &= v + \frac{3}{4} + \alpha + \dots, \\ v^2 &= u + \frac{3}{4} + \beta + \dots. \end{aligned} \tag{2.41}$$

On the plane  $(\alpha, \beta)$ , the bifurcational curves corresponding to the degenerate solutions of system (2.41) have the following form (see Figure 20):

$$\begin{aligned} \alpha &= -\frac{3}{4} + \frac{1}{16t^2} - t + \dots, \\ \beta &= -\frac{3}{4} + t^2 - \frac{1}{4t} + \dots, \end{aligned} \tag{2.42}$$

where  $t$  is some parameter; a triple solution exists when  $t = -1/2$ .

Since

$$\begin{aligned} \frac{3}{4} + \alpha &= \frac{d}{(bc)^{2/3}} \lambda^{-2j/3} \gamma^{4j/3} [y^- \gamma^{-j} - cx^+ \lambda^i + \dots], \\ \frac{3}{4} + \beta &= \frac{d}{(bc)^{4/3}} \lambda^{-4j/3} \gamma^{2j/3} [y^- \gamma^{-k} - cx^+ \lambda^j + \dots], \end{aligned} \tag{2.43}$$

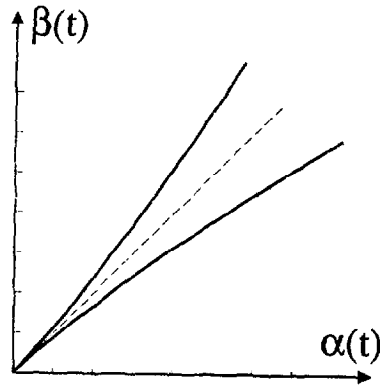

Figure 20. The cusp-point on the plane  $(\alpha, \beta)$ .

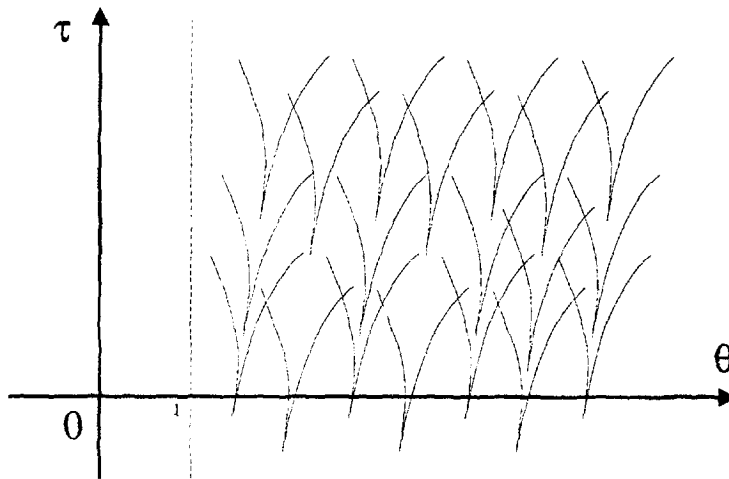

Figure 21. A fragment of the bifurcation diagram on the plane  $(\theta, \tau)$ .

(see (2.38)) and since  $\lambda = \gamma^{-\theta}$ ,  $\gamma^\tau = cx^+/y^-$ , we can write the following formula connecting the values of  $(\alpha, \beta)$  with the values of  $(\theta, \tau)$ :

$$\begin{aligned} \frac{3}{4} + \alpha &= \frac{d}{(bc)^{2/3}} \gamma^{2/3(\theta+2)j} [y^- \gamma^{-j} - y^- \gamma^{\tau-\theta j} + \dots], \\ \frac{3}{4} + \beta &= \frac{d}{(bc)^{4/3}} \gamma^{4/3(\theta+1/2)j} [y^- \gamma^{-k} - y^- \gamma^{\tau-\theta j} + \dots]. \end{aligned} \tag{2.44}$$

This formula allows one to map the curves (2.42) onto the  $(\theta, \tau)$ -plane (see Figure 21).

### 2.9. Cusp-Bifurcations in Two-Parameter Families $f_{\mu, \theta}$

For a two-parameter family  $f_{\mu, \theta}$ , the condition of existence of a triply-degenerate triple-round periodic orbit is written in the form

$$\begin{aligned} j &= \theta i - \tau + \dots, \\ y^- \gamma^{-k} - cx^+ \lambda^j + \mu + \dots &= 0, \end{aligned} \tag{2.45}$$

which is analogous to condition (2.40) obtained for  $\mu = 0$ . One can see that in an arbitrarily small neighborhood of any point  $(\theta, \mu = 0)$ , there exists a point  $(\theta^*, \mu^*)$  for which system (2.45) has an integer solution. This implies that the following theorem holds.

**THEOREM 10.** *In an arbitrarily small neighborhood of any point  $(\theta, \mu = 0)$ , there exists a point  $(\theta^*, \mu^*)$  for which the map  $f_{\theta^*, \mu^*}$  has a doubly-degenerate triple-round periodic orbit.*

Note that  $\mu^*$  can be of arbitrary sign:  $\mu^* < 0$  when  $k > \theta j - \tau$ , and  $\mu^* > 0$  when  $k < \theta j - \tau$ . The corresponding bifurcation diagram is represented in Figure 22.

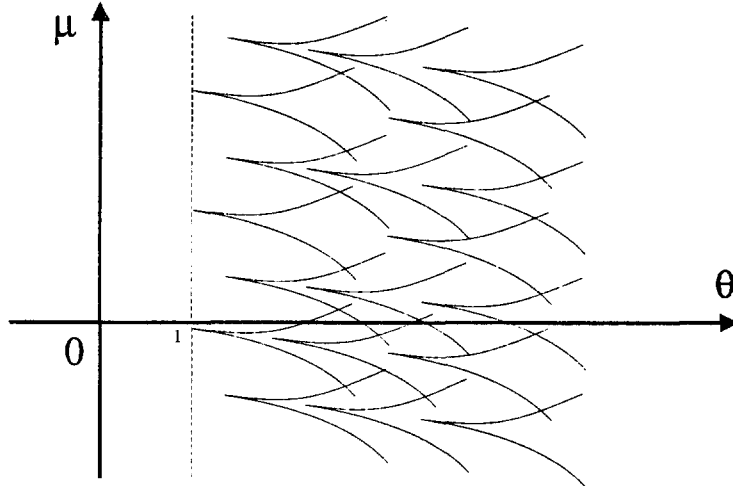

Figure 22. A fragment of the bifurcation diagram on the plane  $(\theta, \mu)$ .

### 3. BIFURCATIONS OF HOMOCLINIC LOOPS TO A SADDLE-FOCUS

In this section, we will examine the dependence of the structure of the bifurcation set of homoclinic loops to an equilibrium point of saddle-focus type on the value of the  $\Omega$ -modulus  $\rho$  for the case of three-dimensional flows. The main results of this section were obtained in [16].

Consider a smooth three-dimensional dynamical system  $X$  satisfying the following conditions:

- A.  $X$  possesses an equilibrium state  $O$  of the saddle-focus type; i.e., the characteristic exponents  $\nu_1, \nu_2, \nu_3$  of  $O$  are such that  $\nu_3 = \gamma > 0$ ,  $\nu_{1,2} = -\lambda \pm i\omega$  ( $\lambda > 0, \omega > 0$ ); and
- B. the saddle index  $\rho = \lambda/\gamma$  is less than 1.

The unstable manifold  $W^u$  of  $O$  is one-dimensional. The point  $O$  divides it into two branches called *separatrices*. All orbits of the two-dimensional stable manifold  $W^s$  have a shape of spirals tending to  $O$  as  $t \rightarrow +\infty$ . We suppose that the following condition is also satisfied:

- C. one of the separatrices (we denote it as  $\Gamma$ ) comes back to  $O$  as  $t \rightarrow +\infty$ , forming a *homoclinic loop* (Figure 1).

Let us consider a sufficiently small neighbourhood  $U$  of the loop.  $U$  is a solid torus composed by a small neighbourhood  $U_0$  of the point  $O$  and by a handle  $U_1$  glued to  $U_0$  as in Figure 4. We are interested in the bifurcations of orbits lying in  $U$ . Since systems with homoclinic loops of a saddle-focus form surfaces of codimension one in the space of dynamical systems, the standard way to study bifurcations of such a system is to include it into a one-parameter family  $X_\mu$ , where  $\mu$  controls the splitting of the loop. The parameter  $\mu$  can be defined as the distance between the point of intersection of  $\Gamma$  with some surface of section and the line of intersection of  $W^s$  with the same surface of section. In this respect, the system forms the loop  $\Gamma$  when  $\mu = 0$ .

When  $\mu$  changes, multi-round homoclinic loops can appear; i.e., such loops that come back to  $O$  after a number of passages along the handle  $U_1$ . In a one-parameter family, bifurcations of such loops were studied in [17,18]. In the present section, we describe bifurcations of homoclinic loops in two-parameter families, and we choose the saddle index  $\rho$  as a second control parameter.

This choice is justified by the fact that the structure of the nonwandering set of systems with homoclinic loops of a saddle-focus depends essentially upon the saddle index  $\rho$  (see [1,2]). Systems with different values of  $\rho$  are not topologically equivalent, so that  $\rho$  is a genuine bifurcational parameter. Moreover, we shall show that the bifurcations of multi-round loops in a one-parameter family  $X_\mu$  depend on the value of the saddle index  $\rho$ .

We start with the bifurcations of double-round loops. As shown in [17], the region  $\mu > 0$ —which corresponds to the inward splitting of the loop—possesses a countable set of smooth curves  $L_j^\rho$

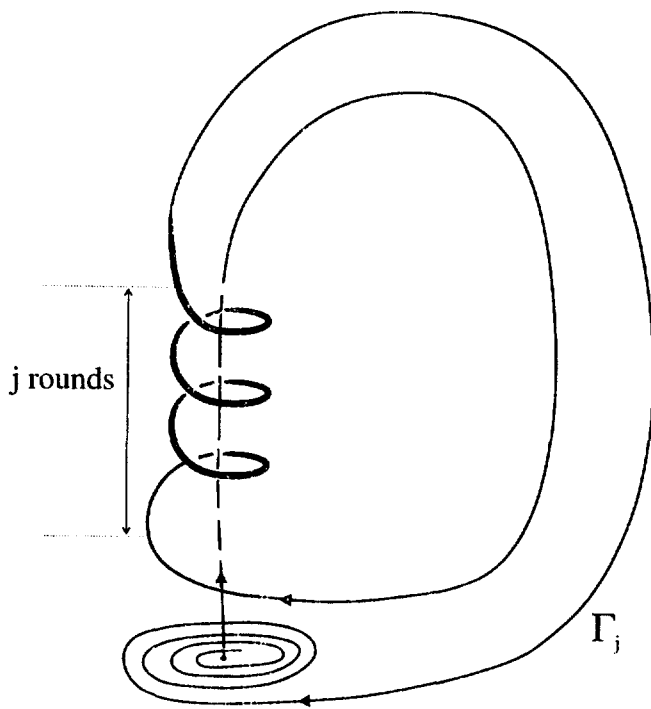

Figure 23. A moment of existence of a double-round homoclinic loop  $\Gamma_j$  to the saddle-focus  $O$  (where the index  $j$  means that the loop circles  $j$  times around  $O$ ).

( $\alpha = 0, 1$ ) of the form  $\mu = f_j^\alpha(\rho) \sim \exp[-\frac{2\pi\rho}{\omega}(j - (1 - \alpha)/2)]$  which correspond to the existence of double-round loops  $\Gamma_j$  (where the index  $j$  means that the loop circles  $j$  times around  $O$ , see Figure 23). In the cases where  $\rho$  is close to one and to zero (the last case corresponding to a pair of pure imaginary characteristic exponents of  $O$ ), the behavior of the curves  $L_j^\alpha$  was studied in [19,20]. It turns out that  $L_j^1$  and  $L_j^0$  merge at some  $\rho = \rho_j^*$  (the greater  $j$ , the closer  $\rho_j^*$  to 1). On the other hand,  $L_j^1$  and  $L_j^0$  have different terminating points at  $\rho = 0$  (Figure 24).

We see that if  $\rho$  lies between 0 and 1, the sequence of bifurcations of double-round loops is the same for all values of  $\rho$  in  $(0, 1)$ . However, this property does not extend to the triple-round loops. Thus, it is established in [16] that for sufficiently large  $j$ , in the region bounded by  $L_{j+1}^0$  and  $L_j^1$ , there exist smooth curves  $L_{jk}^\alpha$ ,  $\alpha = 0, 1$ , corresponding to the existence of triple-round loops  $\Gamma_{jk}$ ; i.e., loops which start with  $O$ , pass along the handle  $U_1$ , circle  $j$  times around  $O$ , pass along  $U_1$  again, circle  $k$  times around  $O$ , pass along  $U_1$  once more and enters  $O$  finally (Figure 25). Each of these bifurcation curves have a vertical tangent at some  $\rho = \rho_{jk\alpha}^*$ , at the left side of which the curve lies entirely (Figure 26). The following asymptotic behaviors hold:

$$\rho_{jk\alpha}^* = \frac{k}{j} + \left( \tau(\rho_{jk\alpha}^*) - \frac{\alpha}{2} \right) \frac{1}{j} + \dots, \quad \text{for } j > k, \tag{3.1}$$

and, when  $j < k$ ,

$$\rho_{jk\alpha}^* = \frac{j}{k - 1/2} + \left( \tau(\rho_{jk\alpha}^*) + \frac{\alpha}{2} \right) \frac{1}{k} + \dots, \quad \text{for } j < k, \tag{3.2}$$

where  $\tau(\rho)$  is a smooth function (see [16]) determined by the system at  $\mu = 0$ . These implicit equations admit solutions when  $j$  and  $k$  are large enough while  $k/j$ , or, respectively,  $j/k$ , is separated from 0 and 1.

Therefore, the following picture takes place for any small segment  $0 < \rho_1 < \rho < \rho_2 < 1$ : in any strip between  $L_{j+1}^0$  and  $L_j^1$ , there is a finite number of curves  $L_{jk}^\alpha$  consisting of two components which are either “parallel” to the  $\rho$ -axis or are connected together and have a parabola-like shape.

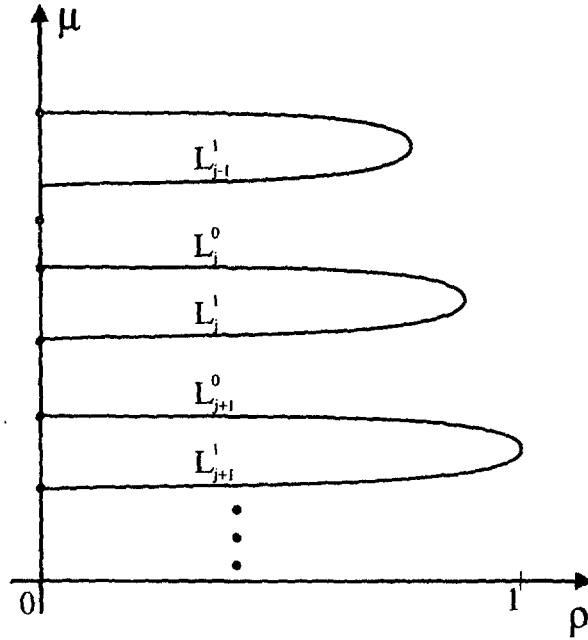

Figure 24. On the parameter plane  $(\rho, \mu)$ , the bifurcational curves  $L_j^\alpha$  ( $\alpha = 0, 1$ ) corresponding to existence of double-round loops  $\Gamma_j$  are represented. The curves  $L_j^1$  and  $L_j^0$  merge at some  $\rho = \rho_j^*$  (the greater  $j$ , the closer  $\rho_j^*$  to 1). On the other hand,  $L_j^1$  and  $L_j^0$  have different terminating points at  $\rho = 0$ .

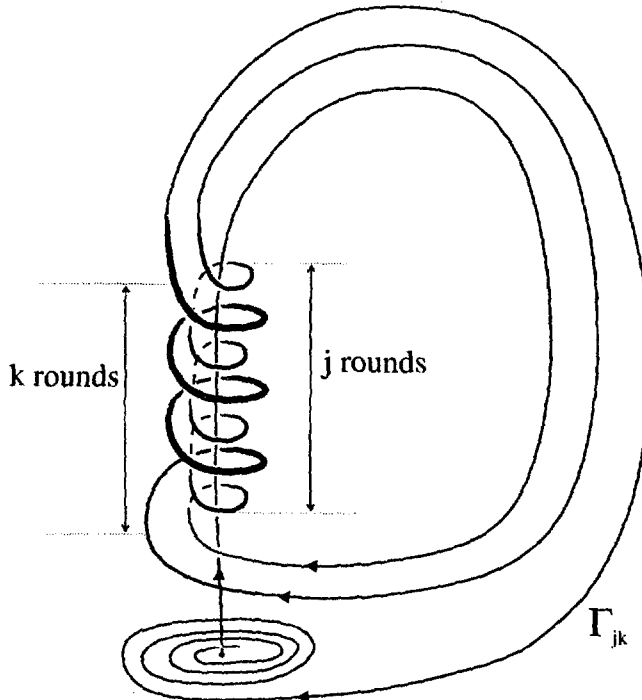

Figure 25. A triple-round loop  $\Gamma_{jk}$ ; i.e., the loop which starts with  $O$ , passes along the handle  $U_1$ , circles  $j$  times around  $O$ , passes along  $U_1$  again, circles  $k$  times around  $O$ , passes along  $U_1$  once more and finally enters  $O$ .

The number of curves of both types grows linearly with the integer  $j$ . The closure of the set  $\{\rho_{jk\alpha}^*\}$  taken for  $j, k$  large enough coincides with the segment  $[0, 1]$ . Therefore, we have the following theorem.

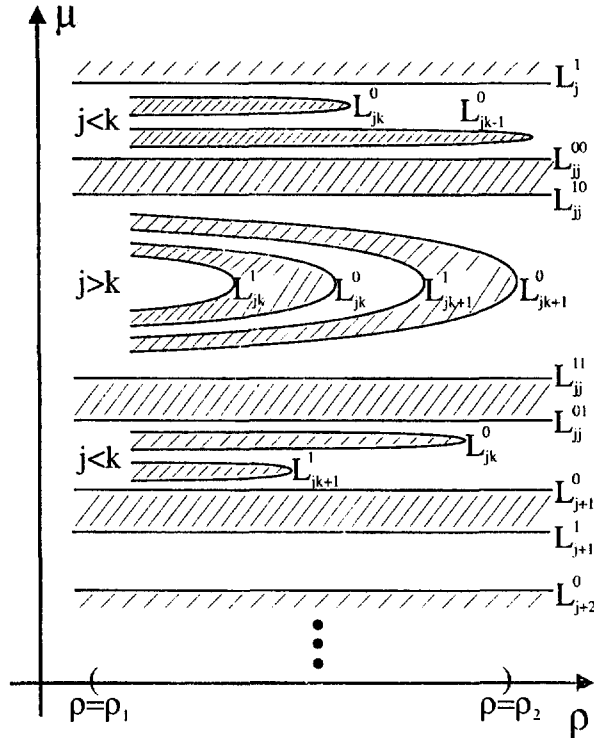

Figure 26. Bifurcational curves  $L_{jk}^\alpha$ ,  $\alpha = 0, 1$ , corresponding to existence of triple-round loops  $\Gamma_{jk}$  are shown in the region of parameters which is bounded by the curves  $L_{j+1}^0$  and  $L_j^1$ .

**THEOREM 11.** [16] *Let  $X_\mu$  be a one-parameter subfamily of  $X_{\mu,\rho}$  with the curve  $\{(\mu, \rho) \mid \rho = \varphi(\mu)\}$  being transverse to the line  $\mu = 0$ . There exists a small variation  $\rho = \varphi(\mu) + \delta$  which makes  $X_\mu$  be tangent to some line of existence of a triple-round homoclinic loop.*

When multiround homoclinic loops are considered, the structure becomes more complicated for the corresponding set of bifurcation curves in the plane  $(\mu, \rho)$ . Indeed, folded lines of nine-round loops accumulate on the lines of triple-round loops in a way similar to the accumulation of the folded (parabola-like) lines of triple-round at the line of single-round loops ( $\mu = 0$ ). It is geometrically evident (see Figure 27) that any curve transverse to  $\mu = 0$  can be varied (in a more general way that in Theorem 1) such that to achieve a cubic tangency with some of these lines of nine-round loops.

Actually, the following general statement holds.

**THEOREM 12.** [16] *Consider a one-parameter subfamily of vector fields  $X_{\mu,\rho}$  with  $\rho = \varphi(\mu)$ , which is transverse to the line  $\mu = 0$  in the plane  $(\rho, \mu)$ . Then, a small smooth perturbation of the curve  $\rho = \varphi(\mu)$  may have a tangency of arbitrarily high order with some of the lines of existence of homoclinic loops.*

This theorem shows the arbitrarily high structural instability of one-parameter families of vector fields near homoclinic loops of a saddle-focus. We emphasize consequences of this result for nonlinear partial differential equations modelling travelling waves in spatially extended systems, what will be discussed below.

Theorems 11 and 12 can also be applied to the theory of nonlinear partial differential equations modelling travelling waves in spatially extended systems. Let us imagine that  $X_{\mu,\rho}$  is a family of ordinary differential equations describing the plane travelling waves of some distributed system;  $\mu$  is the wave velocity while  $\rho$  is an internal parameter of the system. Let the saddle-focus  $O$  be at the origin. It is known that homoclinic loops correspond to self-localised waves in such

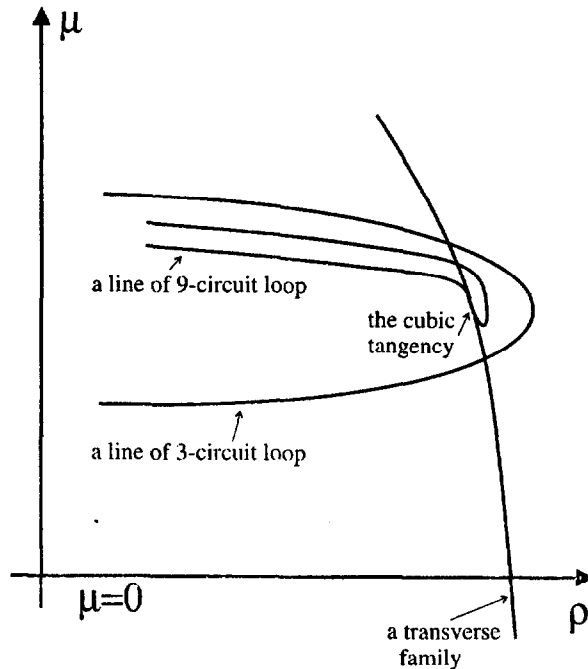

Figure 27. A curve transverse to  $\mu = 0$  has a cubic tangency with a bifurcation curve of existence of a nine-round loop.

systems. Suppose that the system has such a wave and that Conditions A–C of this section are fulfilled for some parameter value  $\mu = \mu_0$ . It follows from Theorem 11 that bifurcations generating “three-pulsed” self-localized travelling waves occur for arbitrary small variations of  $\rho$  in this system. In turn, Theorem 12 implies that the complete description of bifurcations of plane self-localised waves is impossible in systems of such kind.

## REFERENCES

1. L.P. Shil'nikov, A case of the existence of a denumerable set of periodic motions, *Sov. Math. Dokl.* **6**, 163–166 (1965).
2. L.P. Shil'nikov, A contribution to the problem of a rough equilibrium state of saddle-focus type, *Math. USSR Sbornik* **10**, 91–102 (1970).
3. I.M. Ovsyannikov and L.P. Shil'nikov, On systems with a saddle-focus homoclinic curve, *Math. USSR Sbornik* **58**, 91–102 (1987).
4. I.M. Ovsyannikov and L.P. Shil'nikov, Systems with a homoclinic curve of multidimensional saddle-focus type, and spiral chaos, *Math. USSR Sbornik* **73**, 415–443 (1992).
5. J. Palis, A differentiable invariant of topological conjugacies and moduli of stability, *Asterisque* **51**, 335–346 (1978).
6. N.K. Gavrilov and L.P. Shil'nikov, On three-dimensional dynamical systems close to systems with a structurally unstable homoclinic curve I, *Math. USSR Sbornik* **17**, 467–485 (1973); *Math. USSR Sbornik* **19**, 139–156 (1973).
7. S.V. Gonchenko, D.V. Turaev and L.P. Shil'nikov, On models with a structurally unstable homoclinic curve, *Dokl. Acad. Nauk USSR* **320** (2) (1991); English translation in *Soviet Math. Dokl.*, **44**, (2), 422–426, (1992).
8. S.V. Gonchenko, L.P. Shil'nikov and D.V. Turaev, On models with non-rough Poincaré homoclinic curves, *Physica D* **62** (1–4), 1–14 (1993).
9. S.V. Gonchenko and L.P. Shil'nikov, Arithmetic properties of topological invariants of systems with a structurally unstable homoclinic trajectory, *Ukrainian Math. J.* **39** (1), 21–28 (1987).
10. S.V. Gonchenko and L.P. Shil'nikov, Invariants of  $\Omega$ -conjugacy of diffeomorphisms with a structurally unstable homoclinic trajectory, *Ukrainian Math. J.* **42** (2), 134–140 (1990).
11. S.V. Gonchenko and L.P. Shil'nikov, On the moduli of systems with a non-rough Poincaré homoclinic curve, *Russian Acad. Sci. Izv. Math.* **41**, 417–445 (1992).
12. S.V. Gonchenko, Nontrivial hyperbolic subsets of systems with structurally unstable homoclinic curve, (in Russian), In *Methods of the Qualitative Theory of Differential Equations*, pp. 89–102, Gorky State Univ., (1984).
13. L.P. Shil'nikov, On a Poincaré-Birkhoff problem, *Math. USSR Sbornik* **3**, 353–371 (1967).

14. L. Tedeschini-Lalli and J.A. Yorke, How often do simple dynamical processes have infinitely many coexisting sinks?, *Commun. Math. Phys.* **106**, 635–657 (1986).
15. S.V. Gonchenko and L.P. Shil'nikov, On dynamical systems with structurally unstable homoclinic curves, *Soviet Math. Dokl.* **33** (1), 234–238 (1986).
16. O.V. Sten'kin and L.P. Shil'nikov, On the bifurcations of periodic orbits near a structurally unstable homoclinic curve, (in Russian), *Diff. Equations* **33** (3), 377–384 (1997).
17. P. Gaspard, S.V. Gonchenko, G. Nicolis and D.V. Turaev, Complexity in the bifurcation structure of homoclinic loops to a saddle-focus, *Nonlinearity* **10**, 409–423 (1997).
18. P. Gaspard, Generation of a countable set of homoclinic flows through bifurcation, *Phys. Lett.* **97A**, 1–4 (1983).
19. J.A. Feroe, Existence and stability of multiple impulse solutions of a nerve equation, *SIAM J. Appl. Math.* **42**, 235–246 (1982).
20. J.A. Feroe, Homoclinic orbits in a parametrized saddle-focus system, *Physica D* **62**, 254–262 (1993).
21. L.A. Belyakov, A case of the generation of a periodic orbit motion with homoclinic curves, *Mat. Zam.* **15**, 336–341 (1974).
22. L. Belyakov, Bifurcation of systems with homoclinic curve of a saddle-focus with saddle quantity zero, *Mat. Zam.* **36**, 838–843 (1984).